

# ASSEMBLY INSTRUCTIONS

## Value 3/4 Growhouse

### CONTENTS

Main aluminium parts	P1
End sections	P2
Adding the long rails	P3
Squaring	P4
Fitting the back rails	P5
Ground fixing	P6
End plates	P7
Shelving	P8
Fitting liner	P9
Fitting handles	P10
Fitting glass	P11
Troubleshooting	P12
Notes on using the frame	P13

#### Video instructions:

Helpful video clips are available at  
[www.garden-products.co.uk/instructions](http://www.garden-products.co.uk/instructions)



#### Video instructions:

Helpful video clips are available at

[www.garden-products.co.uk/instructions](http://www.garden-products.co.uk/instructions)

#### Can we improve?

We hope that you find our instructions clear and concise. If you have any suggestions for improvements email:

[instructionfeedback@garden-products.co.uk](mailto:instructionfeedback@garden-products.co.uk)

Please keep all packaging until installation is complete

**YOU WILL ALSO REQUIRE CLEAR, OUTDOOR SILICONE SEALANT TO BUILD THIS FRAME**

Access Garden Products  
Crick  
NORTHAMPTON  
NN6 7XS

Tel: 01788 822301  
Fax: 01788 824256  
[sales@garden-products.co.uk](mailto:sales@garden-products.co.uk)  
[www.garden-products.co.uk](http://www.garden-products.co.uk)

Assembly instructions for models: FB4 (3/4 Growhouse)

Date: June 2023 Rev 8 File: FB4

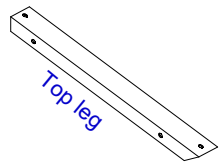

Top leg

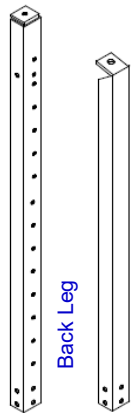

Back Leg

Front Leg

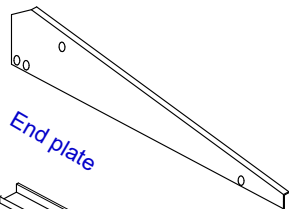

End plate

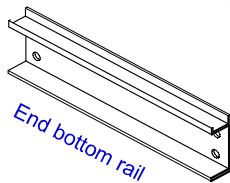

End bottom rail

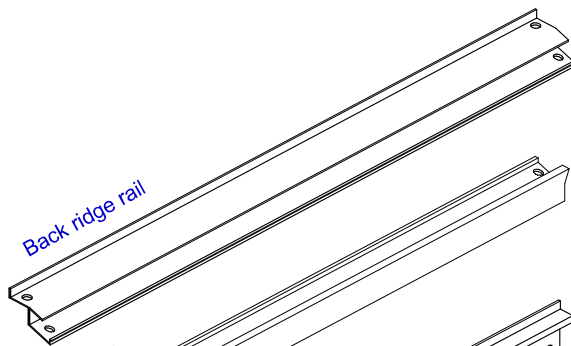

Back ridge rail

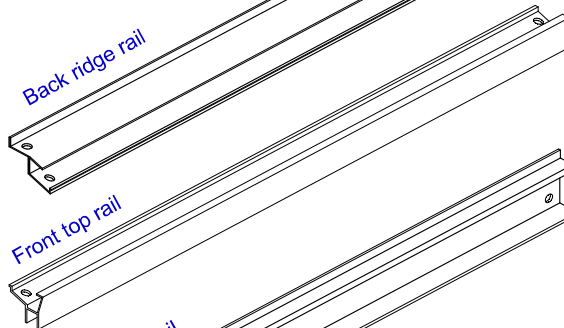

Front top rail



Front bottom rail

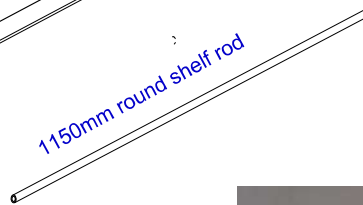

1150mm round shelf rod

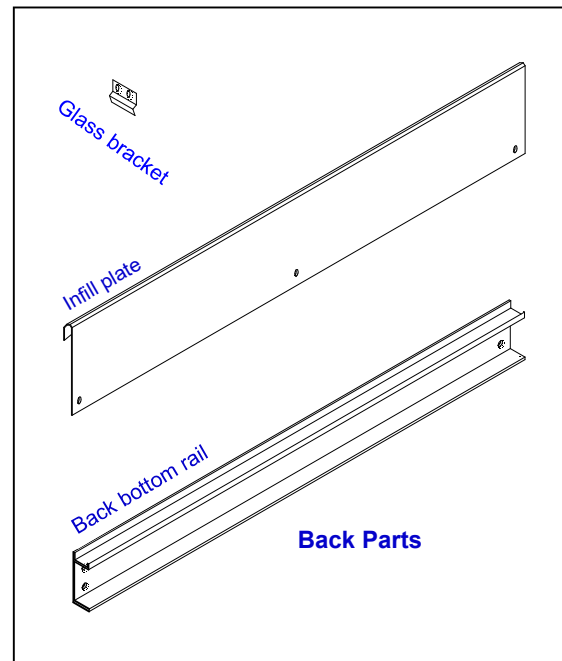

Glass bracket

Infill plate

Back bottom rail

Back Parts

Leg parts	
Back leg	2
Front leg	2
Top leg	2

End parts	
End plate	2
Bottom rail	2

Long parts	
Ridge rail	1
Top rail	1
Bottom rail	2
Infill plate	1
1150mm shelf rod	6



**Powder Coated models only**  
 These have washers supplied to protect the coating - refer to instructions in washer pack

Additional Items		
Handle 585mm		4
Screw pack	SCREW-FB3	1
Ground fixing kit	FR-AKG	1
Shelf pack	S-DVW	1
Black channel liner	W65-5M	1
White channel liner	W66-2M	1
Allen Key	SCREW-FB3	1



Top leg rests against the **FLAT FACE** of back leg— it is not bolted to the back leg

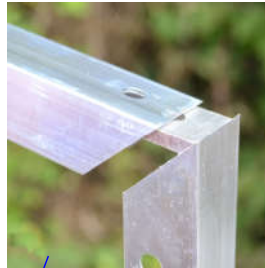

Slide the tongue of the front leg into the groove on the top leg.

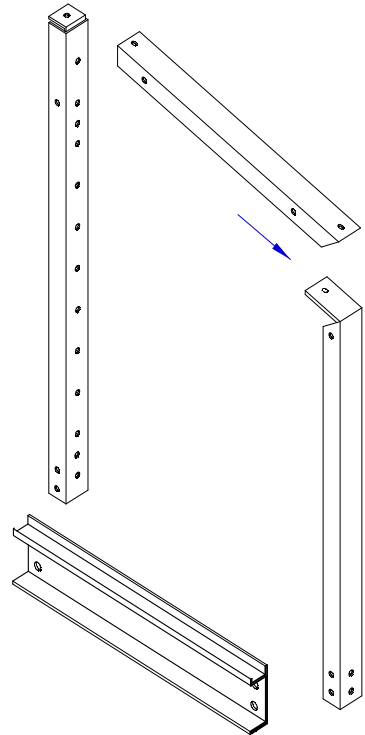

EXPLODED VIEW

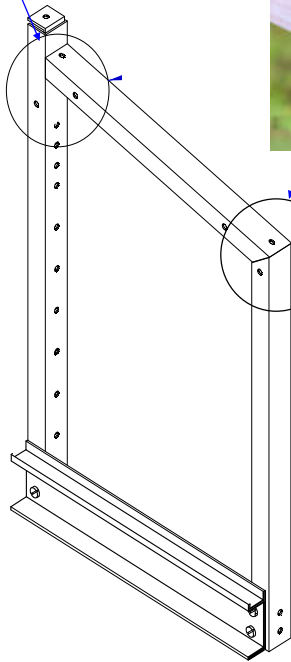

FINISHED LEFT HAND END

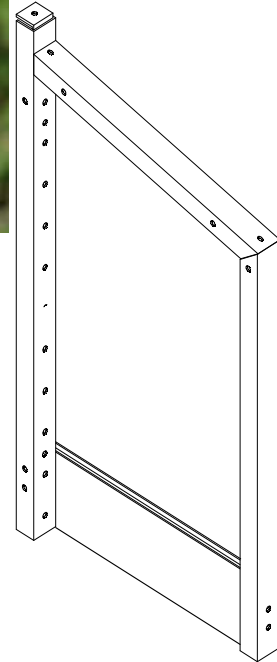

FINISHED RIGHT HAND END

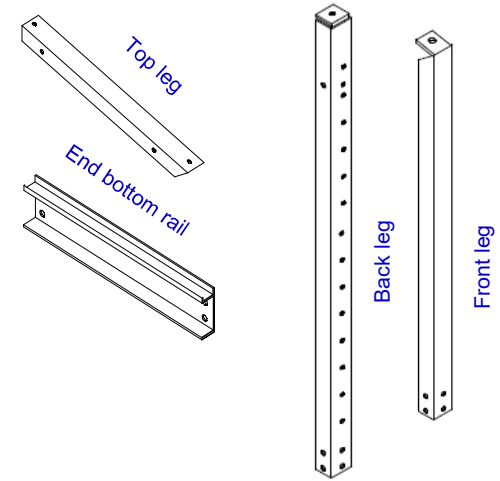

**YOU ALSO NEED:**

10mm BOLTS	4
NUTS	4
Located in pack: SCREW-FB3	

**PARTS NEEDED FOR EACH END**

- 1 Make up the LEFT hand end as shown.
- 2 Make up the RIGHT hand end as shown

Note: Fit the 4 bolts for the bottom end rails loosely, then push the rail upward before nipping up the bolts. This will ensure the glass fits properly.

**DO NOT FULLY TIGHTEN BOLTS AT THIS STAGE**

**END SECTIONS**



FIXING DETAIL



FIXING DETAIL

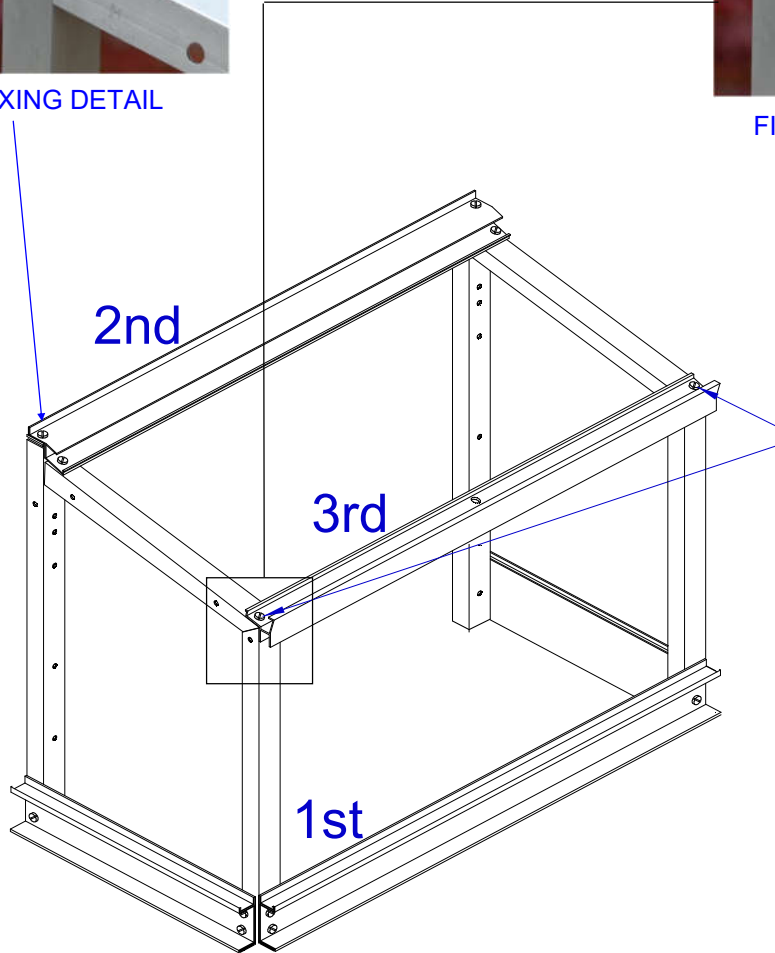

USE THE TWO 20MM BOLTS WITH THIS RAIL

### PARTS NEEDED

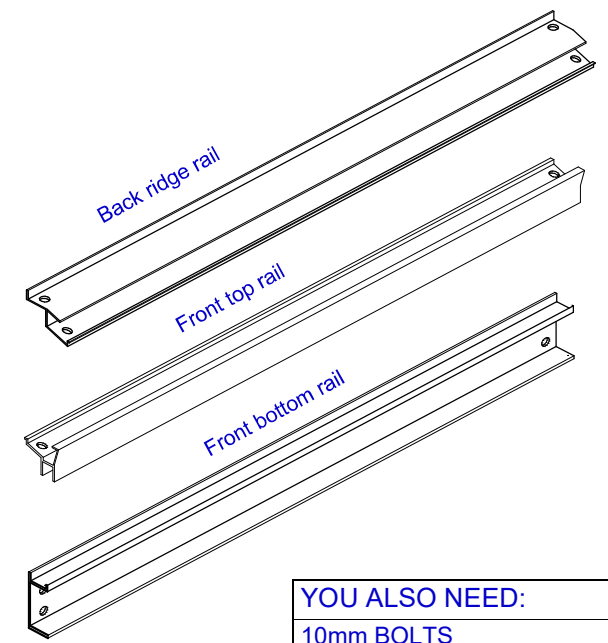

YOU ALSO NEED:	
10mm BOLTS	8
20mm BOLTS	2
NUTS	10
Located in pack: SCREW-FB3	

**1** Bolt on the rails in the order shown.

**DO NOT FULLY TIGHTEN BOLTS AT THIS STAGE**

# 1

## SQUARING THE FRAME

Carefully use a piece of glass to square the unit up as shown. Slacken the nuts if necessary to move the framework into a square position.

Page 11 gives instructions on how to fit the glass into the frame.

**IT IS ESSENTIAL TO GET THE FRAME SQUARE.**

Ensure distance 'A' is equal to distance 'B' otherwise the shelves will not fit.

Carefully remove glass after squaring.

If this nut turns while tightening, use a small pair of pliers to hold the nut

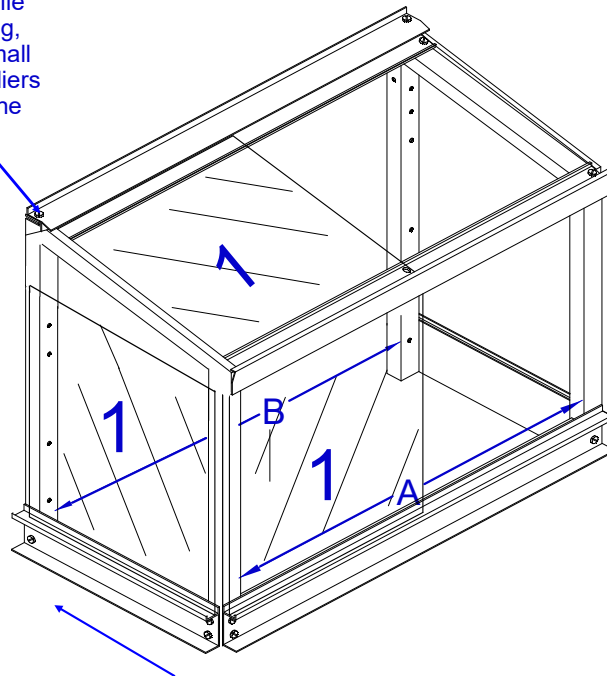

To check the squareness of the end, carefully place a sheet of glass in the channel of the bottom end rail. Do not let the sheet go.

# 2

Once the frame is completely square fully tighten up all the nuts and bolts.

**FULLY TIGHTEN ALL BOLTS**  
otherwise the framework will quickly work loose.

**PERIODICALLY CHECK THE TIGHTNESS OF THE BOLTS**

2

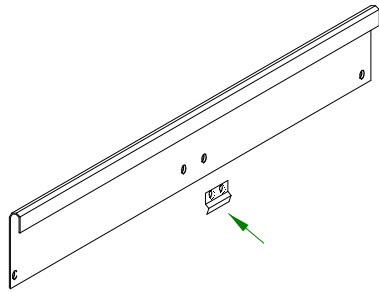

2

**Remove the plastic protective film from the infill plate.** 10mm bolts 'E' goes through the infill plate from the outside. Put a 3mm white spacer on each bolt before pushing on the glass bracket, then fit the nut. Glass bracket is **INSIDE** frame and will clamp onto the glass once the glass is in place.

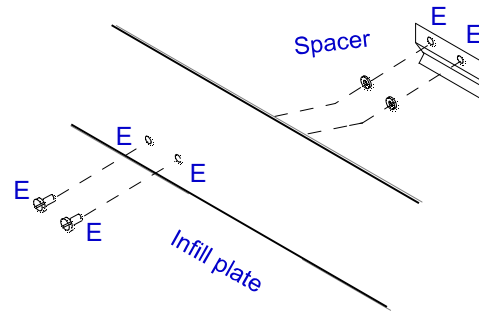

3

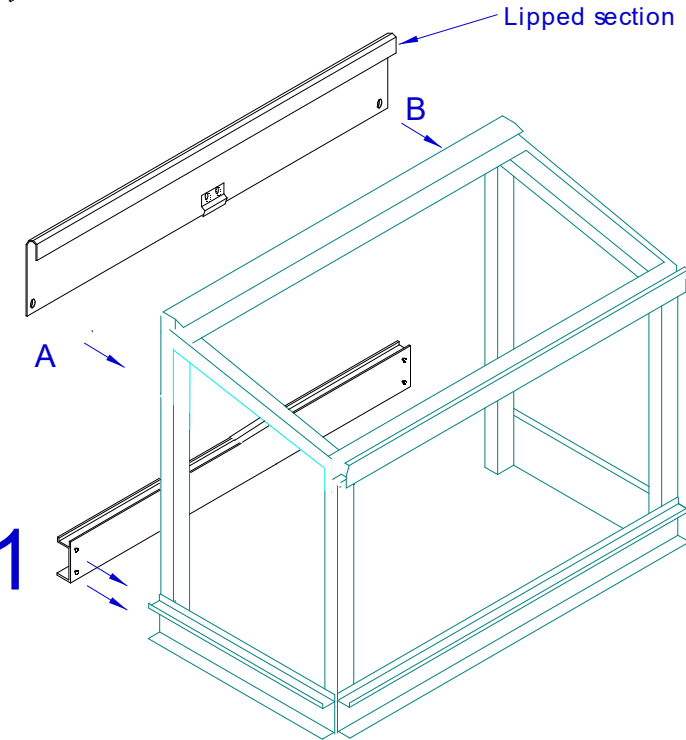

1

Bolt on back bottom rail. Push long bolts through the back bottom rail and back leg, before passing through the leg and fitting nuts on the inside of the frame.



Completed bracket inside Growhouse



Nylon spacers on infill plate

3

Place the lipped section over the upstand on the back rail. Push a long bolt through hole A, then fit a white 3mm spacer and a 20mm nylon spacer. Push the bolt into the frame and fit a nut on the inside of the frame. Repeat for hole B at the other end. **Do not overtighten these bolts.**

## PARTS NEEDED

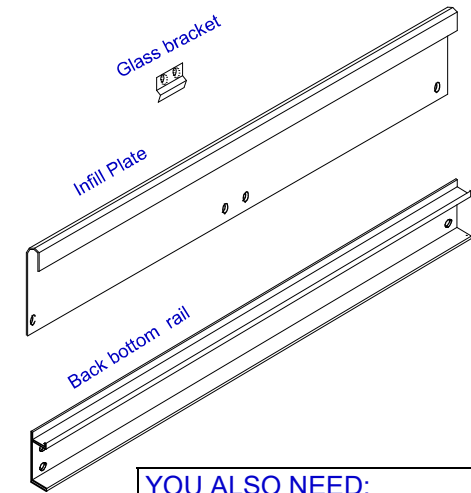

### YOU ALSO NEED:

10mm BOLTS	2
30mm BOLTS	6
NUTS	8
20mm NYLON SPACER	2
3mm WHITE SPACER	4
Located in pack: SCREW-FB3	

**FULLY TIGHTEN  
BOTTOM RAILS ONLY**

1

**FIXING TO FLOOR**

Fit the 'L' brackets to the front legs using a nut and bolt.

Turn the framework upside down and fit the 'L' brackets to the back legs using a nut and bolt.

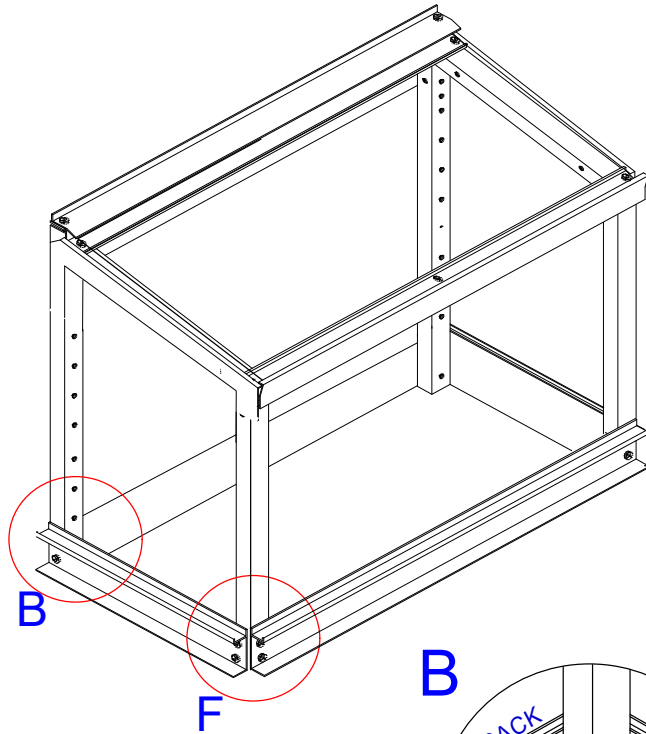

**WEAR APPROPRIATE SAFETY EQUIPMENT WHEN DRILLING OR HAMMERING**

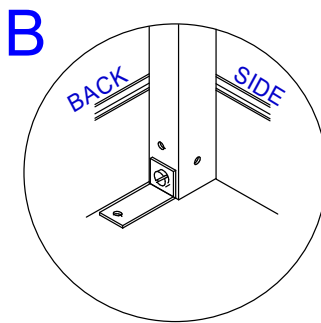

INSIDE VIEW OF BACK LEG SHOWING FIXING

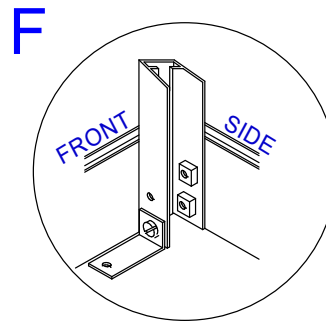

INSIDE VIEW OF FRONT LEG SHOWING FIXING

**PARTS NEEDED**

Ground Fixing Pack FR-AKG

2

Place the framework in its final position and drill through the bracket with a 6mm masonry drill bit, to a depth of 35mm. Insert the red rawplug, through the bracket and into the concrete.

Using a woodscrew, screw through the 'L' bracket and into the rawplug.

Repeat for other brackets.



Completed front bracket

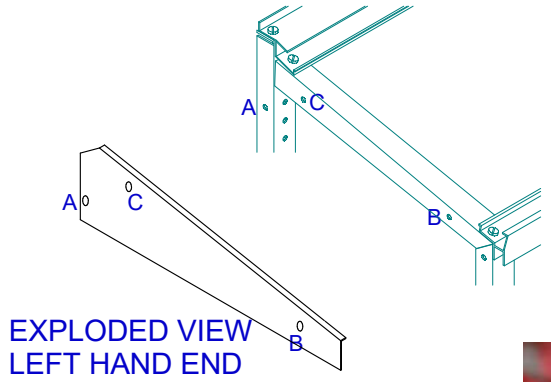

EXPLODED VIEW  
LEFT HAND END

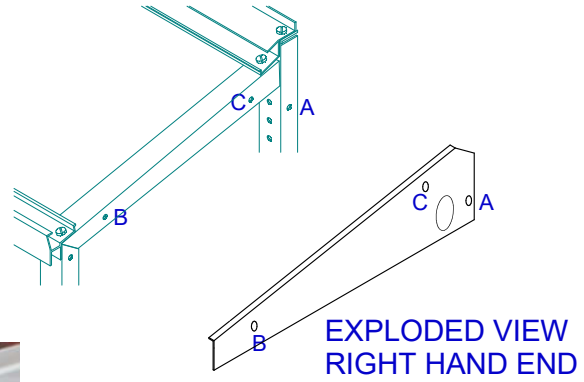

EXPLODED VIEW  
RIGHT HAND END



THE END PLATE  
FITS UNDER THE  
RIDGE RAIL LIP

## FIXING THE END GLASS PANELS

- 1 To provide more rigidity to the end panel of glass, use some clear outdoor silicone sealant to stick the two end sheets of glass in place.
- 2 Mark sure the frame is clean and dry before running a bead of silicone down the front and back leg.
- 3 Place a sheet of 610mm x 950mm glass into the channel of the end bottom leg, then gently push the glass against the sealant.
- 4 Once the glass has firmly stuck to the frame, fit the end plates.

Note: If the glass does not fit under the end plate, slacken the bolts on the bottom end rail and push it upwards.

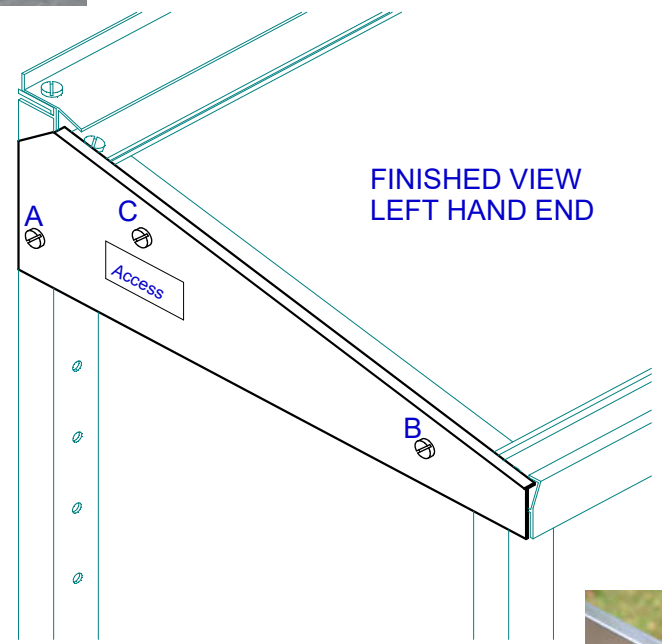

FINISHED VIEW  
LEFT HAND END

THE END PLATE  
FITS UNDER THE  
FRONT RAIL LIP



DO NOT FULLY TIGHTEN  
BOLTS AT THIS STAGE

**PARTS NEEDED FOR EACH END**

YOU ALSO NEED:	
10mm BOLTS	3
NUTS	3
3mm WHITE SPACER	2
BLACK GROMMET	1
Located in pack: SCREW-FB3	

- 1 **Remove any plastic protective film** from the end plates and put 'Access' sticker on.
- 2 Bolts 'A' and 'B' go through the end plate THEN have a 3mm spacer fitted BEFORE fitting to the frame.
- 3 Bolt 'C' only goes through the end plate and the frame.
- 4 Repeat for the other end.
- 5 One end plate will have a large hole in. Fit the black grommet into the hole.



**FB4 models have 2 wide full length shelves as standard.**

As an option, a standard shelf unit can also be added.

- 1** Lightly tap rawlplug inserts into both ends of the tubular aluminium shelf rods with a hammer.
- 2** Slide the two hooks onto the tube, as shown then screw the support bracket on at each end.
- 3** Fit the other rods to the shelf.

### FITTING



Hook support wire into top hole, then swing shelf upward into the adjacent hole below.

### PARTS NEEDED

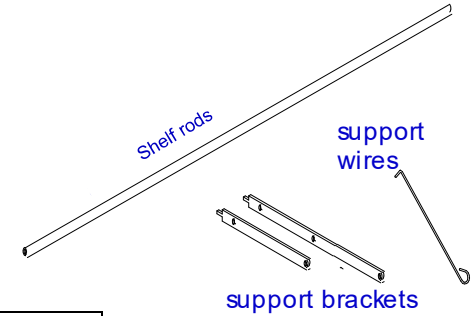

**YOU ALSO NEED PER SHELF ROD:**

RAWLPLUGS	2
1" WOOD SCREW	2
Located in packs: S-DVW	

**NEW 5-hole strap**  
Fit the rods to the holes 'F'

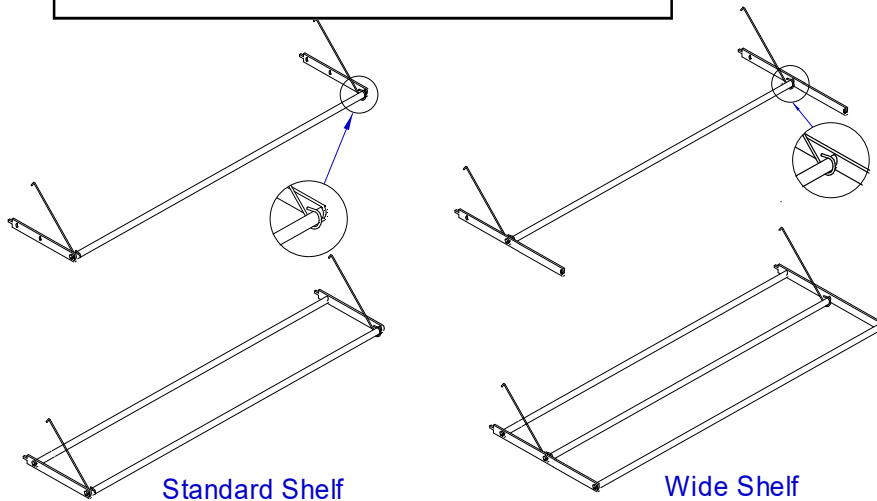
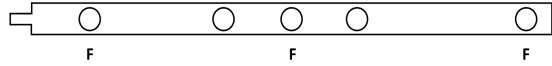

When the shelves are not needed they can either be removed or they can be unhooked from the lower fixing hole and hung flat against the back using the wires.



Bottom shelf hung flat against the back

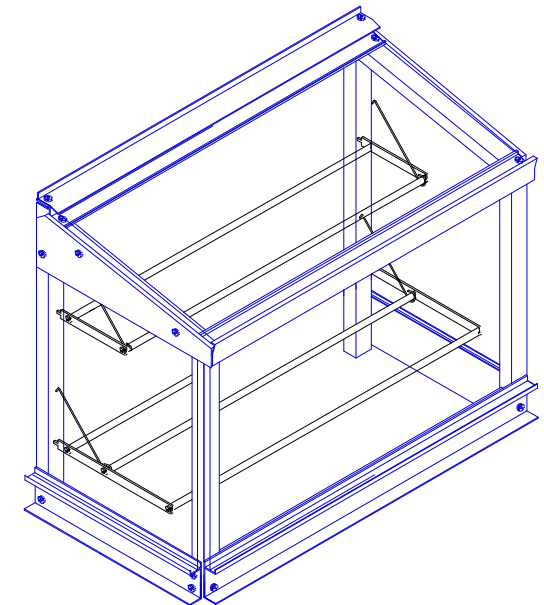

Note: A Pozidrive screwdriver will fit the screws best

# FITTING THE CHANNEL LINER

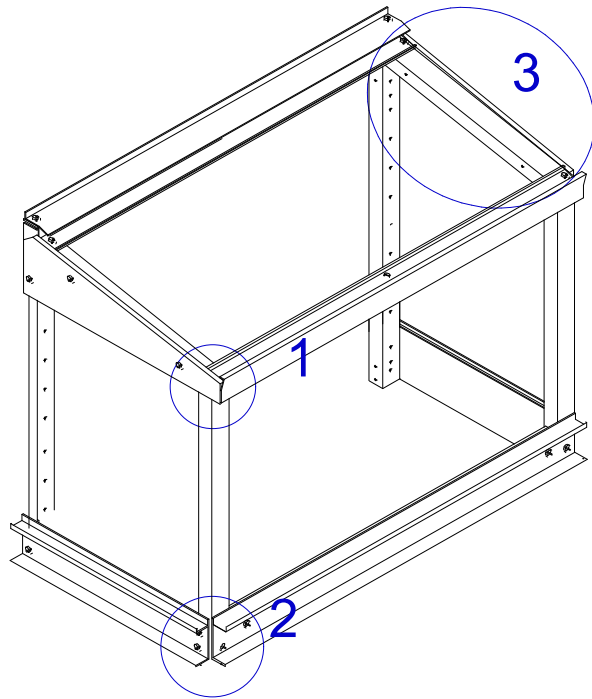

**1** The white liner (W66-2M) fits on the inside vertical face of top FRONT rail only. This is a loose fit so strips of double sided tape are included to secure it until the glass is in place.

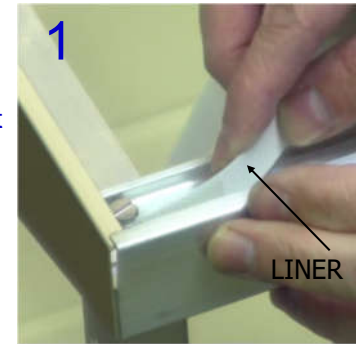
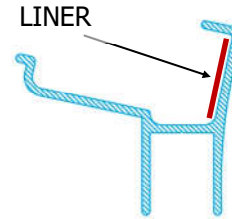

**2** The black plastic liner (W65-5M) goes in the FRONT bottom rail only. Using the strips of double sided tape press liner down so that it LIES FLAT at the bottom of the channel - trim with a knife if necessary.

THE DOORS WILL NOT SLIDE PROPERLY IF THE LINER IS NOT FLAT

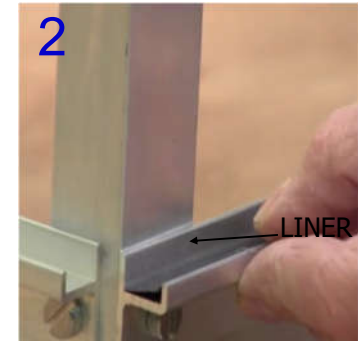

**3** To make the top glass slide more easily, rub candle wax onto the glass bearers. Also wax the black and white liners.

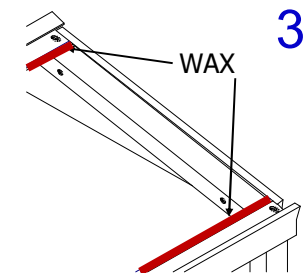

**TIP:** Before sticking the tape, clean the aluminium of any oil traces to promote adhesion.

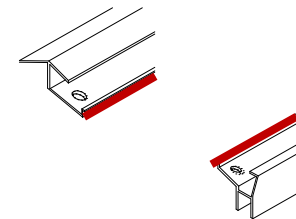

# FITTING THE HANDLES

When fitting the handles, place the glass on a table or timber battens.  
**NEVER PLACE THE GLASS DIRECTLY ON CONCRETE OR SLABS**

## WARNING

If broken, toughened glass will fragment safely.

If the edges are knocked or chipped the glass will spontaneously fragment. This is a natural occurrence due to the toughening process. Care should be taken when moving or cleaning, not to damage the edge of the glass.

When placing the glass in the frame, ensure that the glass is securely placed in the runners before letting go of the glass.

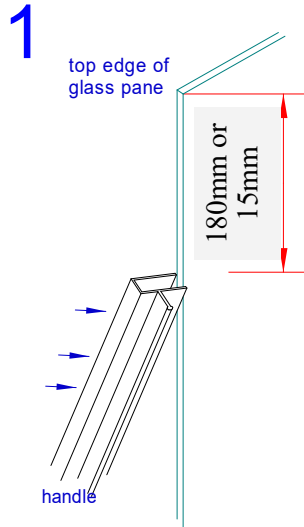

First wipe the edge of the glass where the handle will fit with a wet cloth.

Then slide the handle over the edge of the glass, starting at the top corner of the handle.

For the 950mm sheets, place the handle 180mm from the top edge of the glass. For the 610mm roof glass, place the handle 15mm from the top edge.

610mm sheets requiring handles	2
950mm sheets requiring handles	2

GLASS	FB4
610mm x 610mm	2
950mm x 610mm	6

**TIP:** Always grip the handle in the **CENTRE** when sliding



Work on handle from side edge

**TIP:** Do not try and slide the handle on from the top or bottom

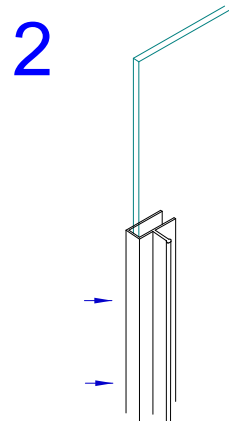

Work the handle fully onto the glass.

**DO NOT** lift the glass by the handle

Always grip the handle in the **CENTRE** when sliding

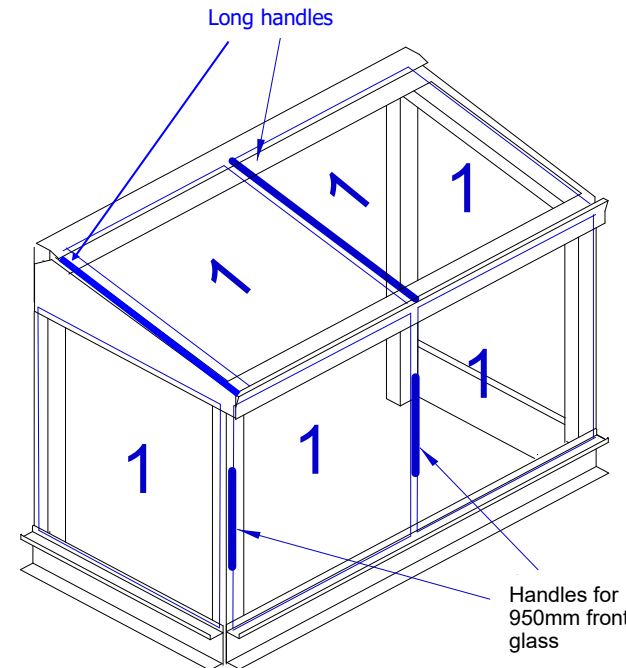

Handles for 950mm front glass

End and back glass have no handles

## FITTING HANDLES

Fit the handles to the glass before fitting into the frame. Ensure the handles are always on the left hand side of the glass.

## FITTING THE GLASS (FRONT AND TOP)

To fit the glass push the sheet into the deeper top channel, then lower into the bottom channel (C). Make sure the glass is firmly in the bottom channel before letting go. Always start glazing at the left hand end and overlap each subsequent pane by 1" (2cm)

## END GLASS

End glass should be fitted once the framework has been squared—see page 7. Fit a ring wedge (D) into the bottom glass channel - 1 per sheet.

## BACK GLASS

Slacken the four infill plate bolts and gently slide the first sheet in from the rear corner. Gently slide the other sheet in from the other end. The two sheets will overlap in the centre, behind the glass bracket (B). Carefully retighten the bolts. Fit a ring wedge (D) into the bottom glass channel - 1 per sheet.

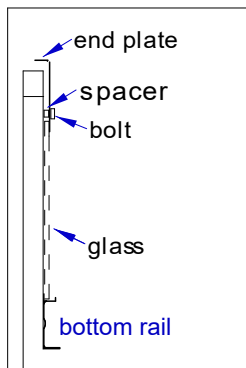

A. End glass detail

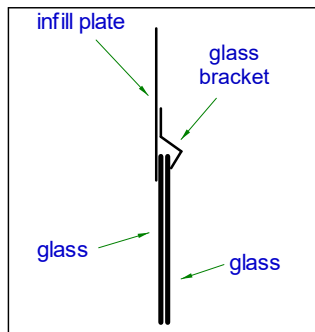

B. End glass overlap detail



B. Glass bracket



C. Fitting the glass



D. Ring wedge  
(Located in pack: SCREW-FB3)

GLASS STICKS TOGETHER	This is normally due to the handles not being put on the correct side of the glass. See page 10 for details of where the handles should be fitted to the glass.
HANDLES COME OFF	<p>As the handles are of a clamp design they can be pulled off if too much force is applied to them. If the glass has stuck together due to moisture, or if the glass does not slide smoothly, this will strain the handle and cause it to come off.</p> <p>Ensure that the channels and the glass are kept clean at all times to minimise the sliding force needed. Candle wax applied to the channel and the underside of the glass will also help the sliding action. Also check that the handles have been fitted correctly. See page 10 for full instructions.</p> <p>Sometimes the soft plastic gets a layer of dirt on it that prevents it from gripping the glass. If this is the case the handle will just slide on and slide off with almost no grip. If the handle comes off easily, take the handle off and wipe the two strips of very soft plastic with a damp cloth.</p> <p>If handles come off frequently either purchase some new handles from Access or use a glue such as 'liquid nails' or 'no more nails' to permanently glue the handles to the glass.</p>
SHELVES WILL NOT FIT INTO THE BACK LEGS	<p>Check that the back legs have been fitted the right way round - see page 2.</p> <p>Check that dimension A = B - see page 4.</p>
FRAMEWORK MOVES AND GLASS FALLS OUT	<p>If the nuts and bolts haven't been properly tightened, the framework will quickly become loose and move, even in light winds. In strong winds the glass will fall out. Remove the glass, re-square the frame, then <b>fully tighten all of the nuts and bolts.</b></p>

**PERIODIC MAINTENANCE** Every Spring take the glass out of the greenhouse and wash glass and framework with warm soapy water. When inserting the glass, always check that the glass is properly seated in its top and bottom channels before letting go of the sheet.

**CHECK THE TIGHTNESS** of all bolts regularly, especially in very windy areas or powder coated frames.

**CROP ROTATION** Suggestions for suitable crops and sowing dates given in the free Access Growing Guide

**VENTILATION** In cold weather gentle ventilation can be given by sliding the front sheets of glass to give 2-3" (5-8cm) gap at each corner.

In warmer weather allow a gap on the top sheets as well. In very hot weather open all the sheets of glass. To ensure that the correct temperature is maintained use a thermometer inside the greenhouse. You can completely remove the top sheets in summer.

**GALES** The greenhouse must be kept fully closed in rough weather.

**GLASS CHANNELS** Ensure that this is kept free from debris and allows the glass to slide smoothly. Periodically lubricate the running edge of the glass with a wax candle.

**SNOW** If snow is very heavy - avoid letting it build up on the roof

**SHELVING** Stand pot plants on saucers, or use optional shelf covers which incorporate a layer of capillary matting to absorb excess water when watering. Alternatively, stand the pots in empty seed trays.

**SITING** Site on the sunniest place available. Anything from East through South to West. is suitable. If it has to face North, don't despair, it will be warmer in than outside! If you can fix to a brick or stone wall, you will get extra heat storage during the day.

**REDUCING THE LENGTH** If it is just too long for your ideal spot, it can be shortened. Re-drill the holes at one end of the rails - moving them in by the amount you need to remove. Hacksaw off the surplus aluminium and shorten the shelf rods. The glass will merely overlap more - don't try to cut toughened glass!