

# ASSEMBLY INSTRUCTIONS

## Westminster

### CONTENTS

Main aluminium parts	P1
End sections	P2
Adding the long rails	P3
End plates	P4
Centre legs	P5
Squaring & fixing	P6
Wall & floor problems	P7
Shelving	P8
Fitting liner	P9
Fitting handles	P10
Fitting glass	P11
Fitting corner trim	P12
Troubleshooting	P13
Notes on using the frame	P14

Please keep all packaging  
until installation is complete



#### Video instructions:

Helpful video clips are available at

[www.garden-products.co.uk/instructions](http://www.garden-products.co.uk/instructions)

#### Can we improve?

We hope that you find our instructions clear and concise. If you have any suggestions for improvements email:

[instructionfeedback@garden-products.co.uk](mailto:instructionfeedback@garden-products.co.uk)

Access Garden Products  
Crick  
NORTHAMPTON  
NN6 7XS

Tel: 01788 822301  
Fax: 01788 824256  
[sales@garden-products.co.uk](mailto:sales@garden-products.co.uk)  
[www.garden-products.co.uk](http://www.garden-products.co.uk)

Assembly instructions for models: Westminster AN5 (1.00m/3'4") BN5(1.51m/5'0")

Date: June 2023 Rev: 7 File: N5

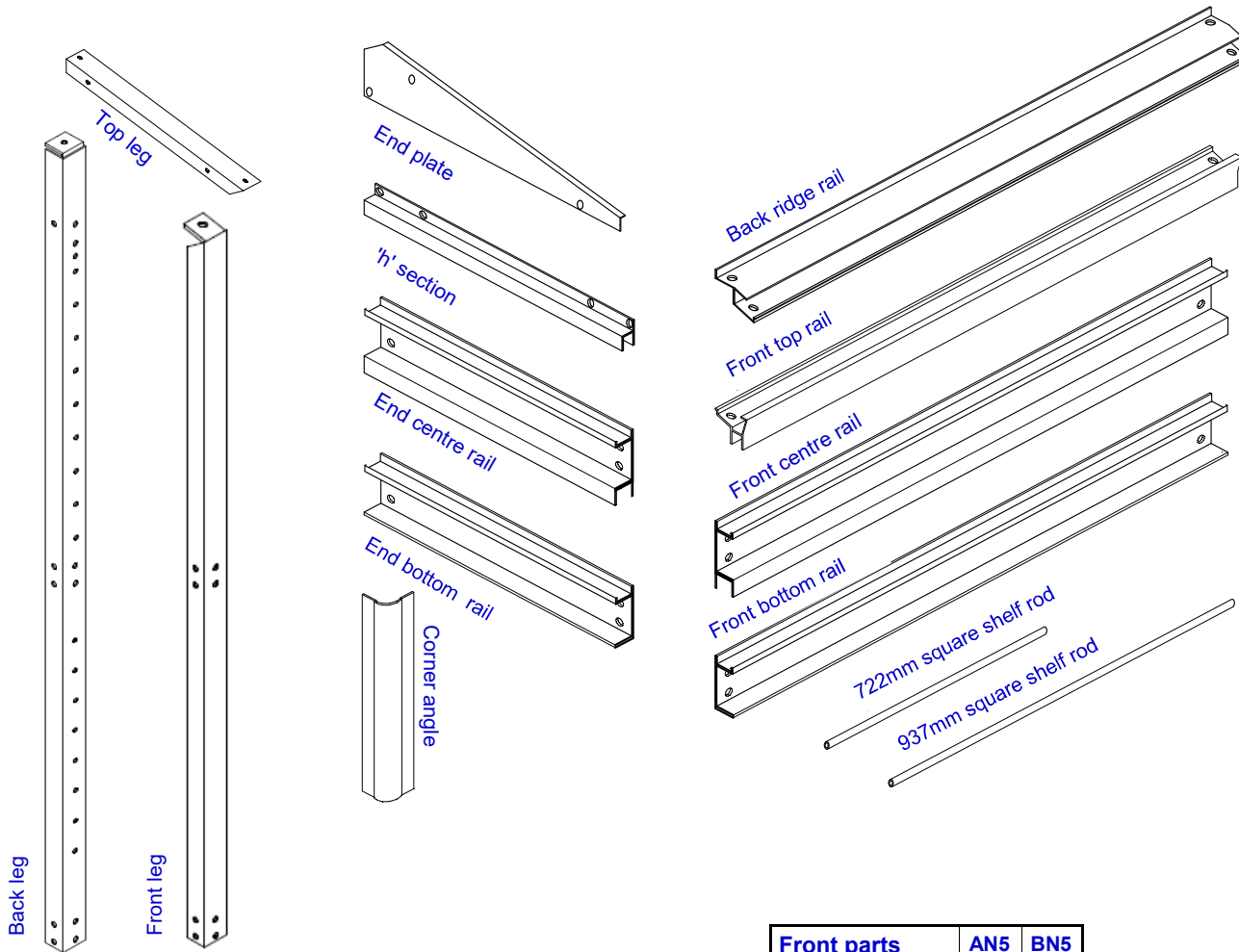

**FIT THE WASHER UNDER THE HEAD OF ALL HEX HEAD BOLTS UNLESS OTHERWISE INSTRUCTED.**

Leg parts	AN5	BN5
Back leg	2	3
Front leg	2	3
Top leg	2	3

End parts	AN5	BN5
End plate	2	2
'h' section	2	2
Centre rail	2	2
Bottom rail	2	2
Corner Angle	4	4

Front parts	AN5	BN5
Ridge rail	1	1
Top rail	1	1
Centre rail	1	1
Bottom rail	1	1
722mm shelf rod	0	24
937mm shelf rod	15	0

Additional Items		AN5	BN5
Handle 725mm		6	6
Screw pack	SCREW-H1	1	1
Wall fixing pack	FR-WF6	1	1
Front anchorage pack	FR-AK	1	1
Standard shelf pack	S-N1	1	2
Standard shelf pack	S-N2	2	4
Trim pack	TRIM-4	2	2
Black channel liner	W65-5M	1	1
White channel liner	W66-2M	1	1
Allen Key	SCREW-H1	1	1



Top leg rests against the **FLAT FACE** of back leg—it is not bolted to the back leg



Slide the tongue of the front leg into the groove on the top leg.



DEEPER CHANNEL AT BOTTOM

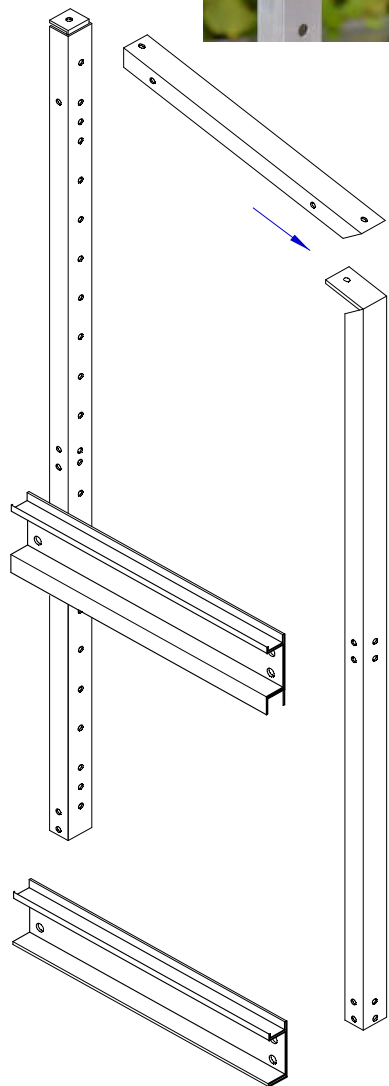

EXPLODED VIEW

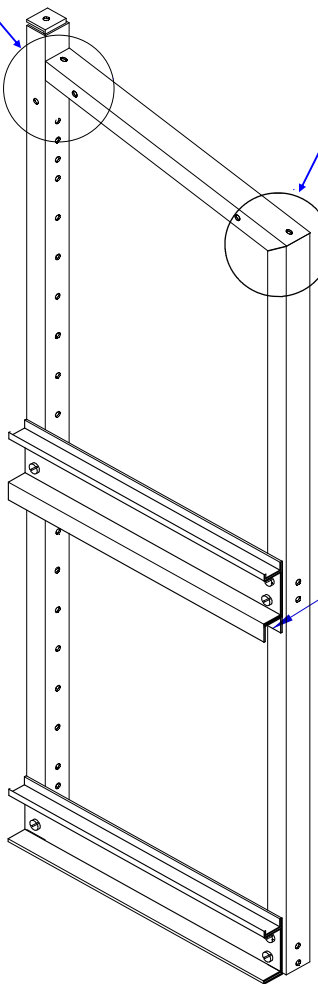

FINISHED LEFT HAND END

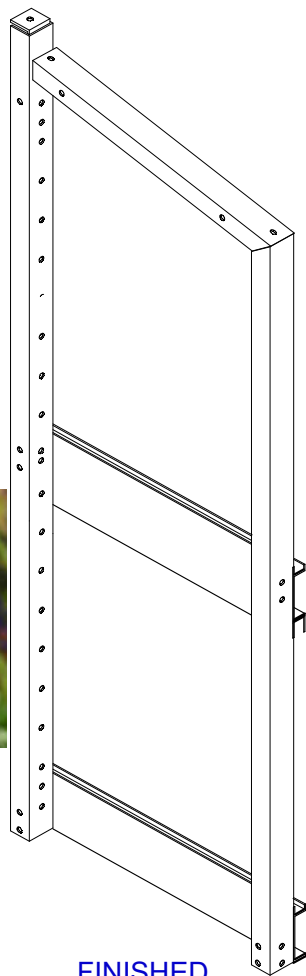

FINISHED RIGHT HAND END

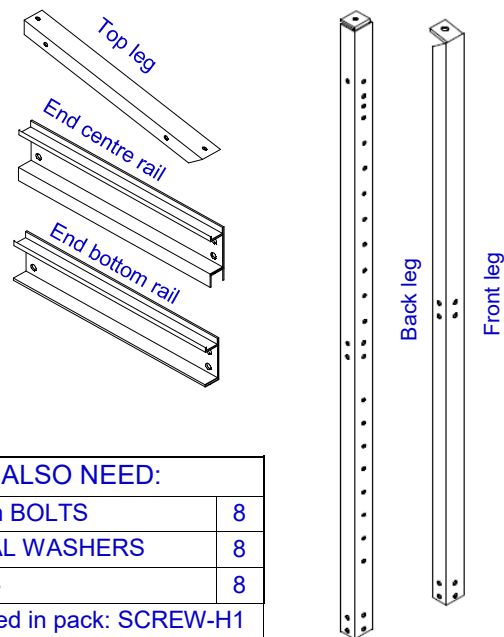

**YOU ALSO NEED:**

10mm BOLTS	8
METAL WASHERS	8
NUTS	8
Located in pack: SCREW-H1	

**PARTS NEEDED FOR EACH END**

- 1 Make up the LEFT hand end as shown.
- 2 Make up the RIGHT hand end as shown

**DO NOT FULLY TIGHTEN BOLTS AT THIS STAGE**

**END SECTIONS**



FIXING DETAIL

**DO NOT FIT A WASHER AT POINTS MARKED X**  
 ON POWDERCOATED UNITS TAKE CARE NOT TO OVERTIGHTEN THESE BOLTS OTHERWISE THE COATING WILL BE DAMAGED

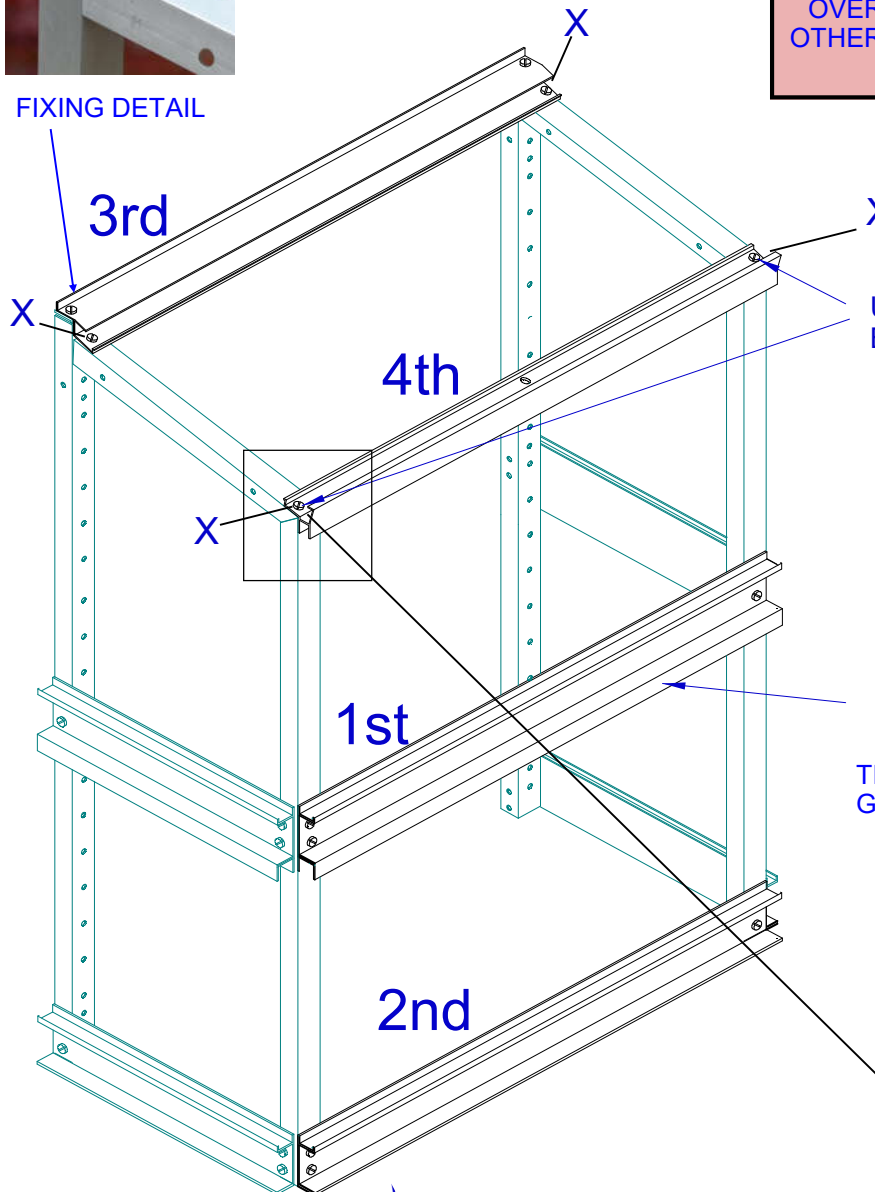

USE THE TWO 20MM BOLTS WITH THIS RAIL



THE DEEPER CHANNEL GOES AT THE BOTTOM



FIXING DETAIL

**PARTS NEEDED**

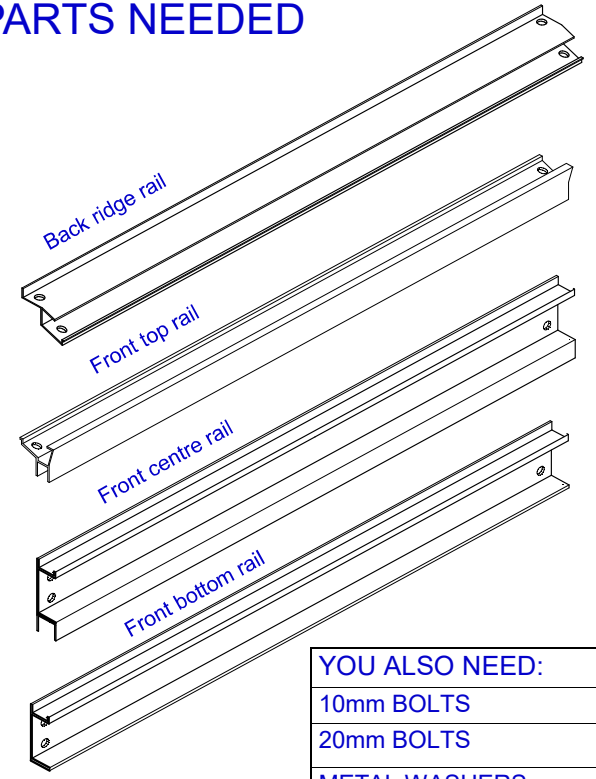

**YOU ALSO NEED:**

10mm BOLTS	12
20mm BOLTS	2
METAL WASHERS	8
NUTS	14
Located in pack: SCREW-H1	

**1** Bolt on the rails in the order shown.

**DO NOT FULLY TIGHTEN BOLTS AT THIS STAGE**

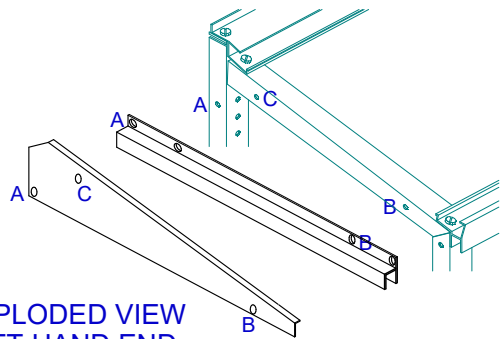

EXPLODED VIEW  
LEFT HAND END

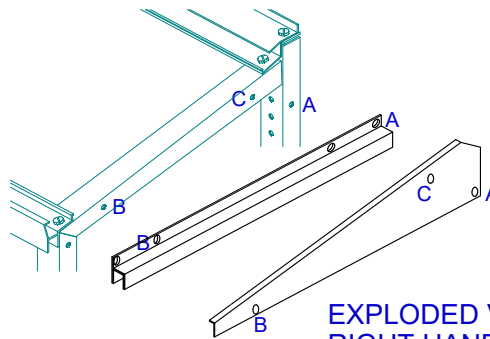

EXPLODED VIEW  
RIGHT HAND END

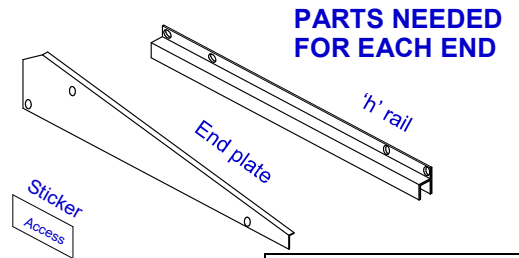

**PARTS NEEDED  
FOR EACH END**

**YOU ALSO NEED:**

10mm BOLTS	3
METAL WASHERS	3
NUTS	3
Located in pack: SCREW-H1	



THE END PLATE  
FITS UNDER THE  
RIDGE RAIL LIP

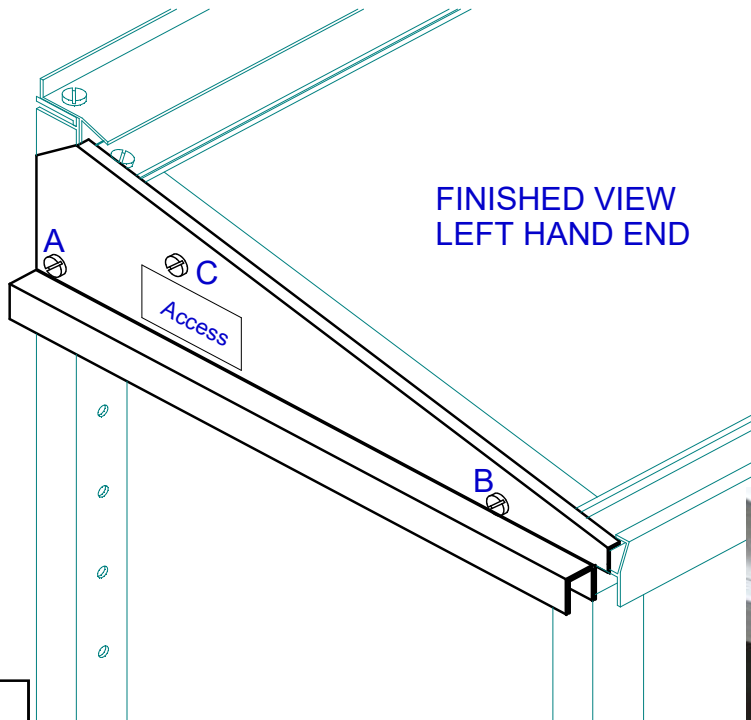

FINISHED VIEW  
LEFT HAND END



THE END PLATE  
FITS UNDER THE  
FRONT RAIL LIP

- 1 **Remove any plastic protective film** from the end plates and put 'Access' sticker on.
- 2 Make up the LEFT hand end as shown.
- 3 Make up the RIGHT hand end as shown.

**NB** Bolt 'C' only goes through the end plate and the frame.

IF YOU HAVE  
AN AN5 MODEL  
GO TO PAGE 6

DO NOT FULLY TIGHTEN  
BOLTS AT THIS STAGE

DO NOT FIT A WASHER AT THE 2 POINTS MARKED X IF POWDERCOATED TAKE CARE NOT TO OVERTIGHTEN BOLT AS WILL DAMAGE PAINT

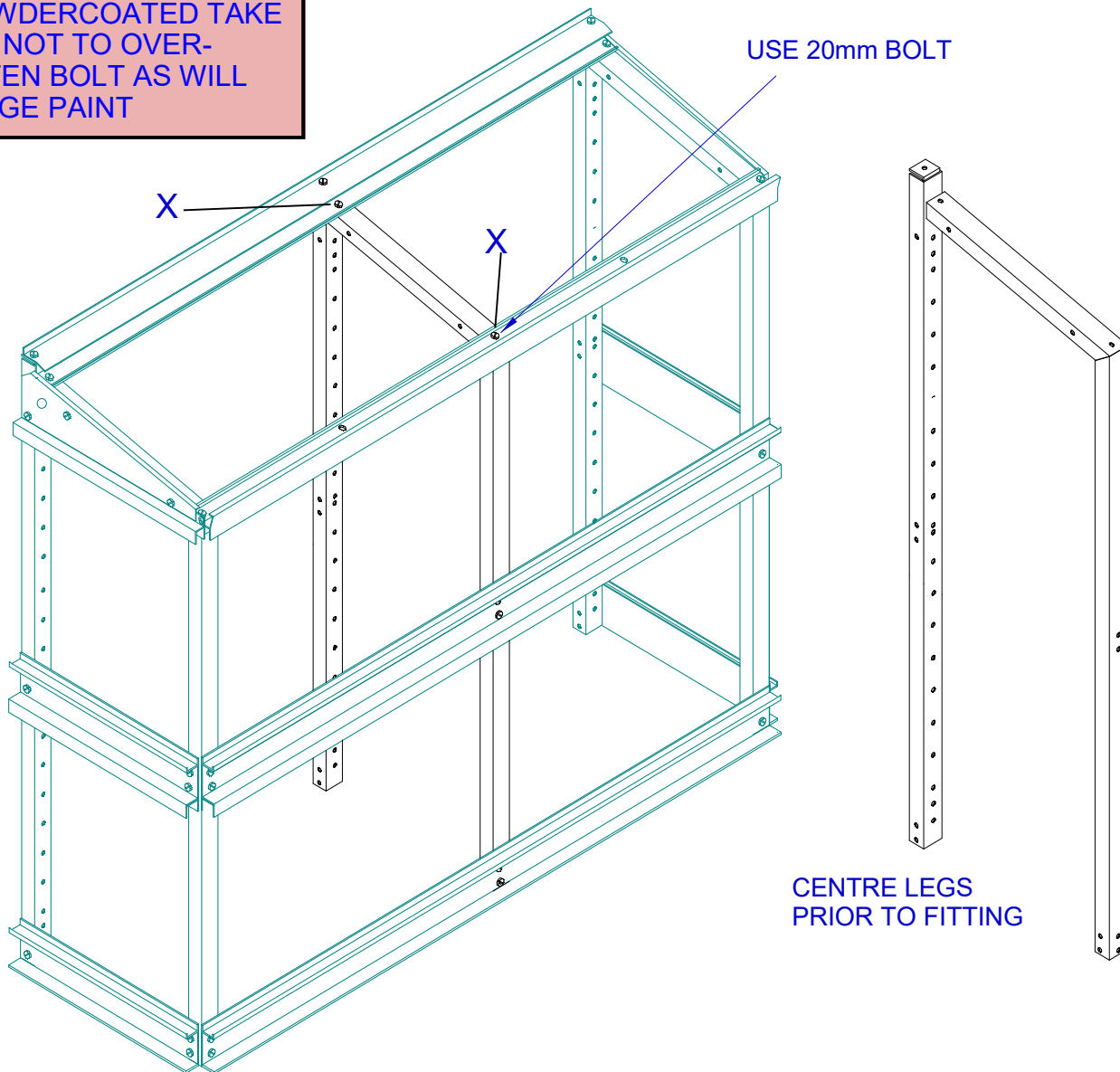

USE 20mm BOLT

X

X

CENTRE LEGS  
PRIOR TO FITTING

## PARTS NEEDED

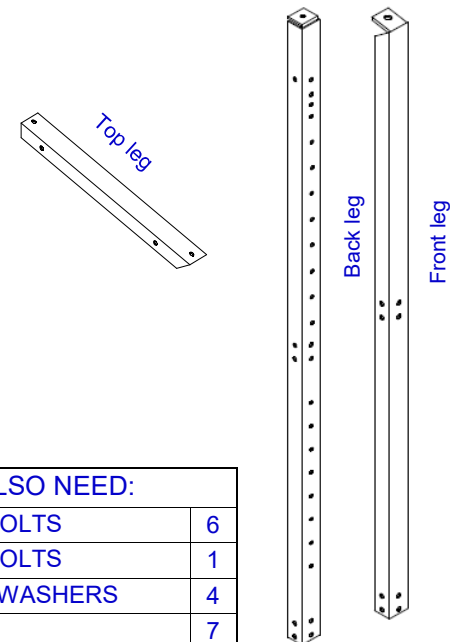

YOU ALSO NEED:	
10mm BOLTS	6
20mm BOLTS	1
METAL WASHERS	4
NUTS	7
Located in pack: SCREW-H1	

**1** Fit legs as shown into the frame.

DO NOT FULLY TIGHTEN BOLTS AT THIS STAGE



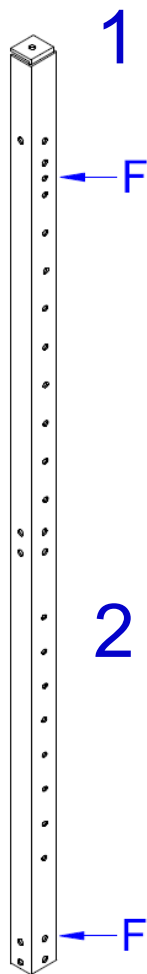

1

### SQUARING THE FRAME

Use a piece of glass to square the unit up as shown. Slacken the nuts if necessary to move the framework into a square position.

IT IS ESSENTIAL TO GET THE FRAME SQUARE. DO NOT ALIGN TO THE WALL AS IT MAY NOT BE SQUARE .

Ensure distance 'A' is equal to distance 'B' otherwise the shelves will not fit.

Once the frame is completely square tighten up all the nuts.

Remove glass once squaring is complete.

### FIXING TO WALL

Two hammer fix screws are used in each 'back leg' (pack FR-WF6).

Counting from the floor the screws go in the holes marked 'F'

Holes 2 & 22

Using a 6mm masonry bit drill, mark the drill at a depth of 65mm. With the unit against the wall, drill through the holes (F) until the mark reaches the hole in the 'back leg'. Push the COMPLETE screw and rawplug through the hole in the back leg and into the wall.

Lightly hammer or screw in with a 'phillips head' screwdriver.

FULLY TIGHTEN ALL BOLTS

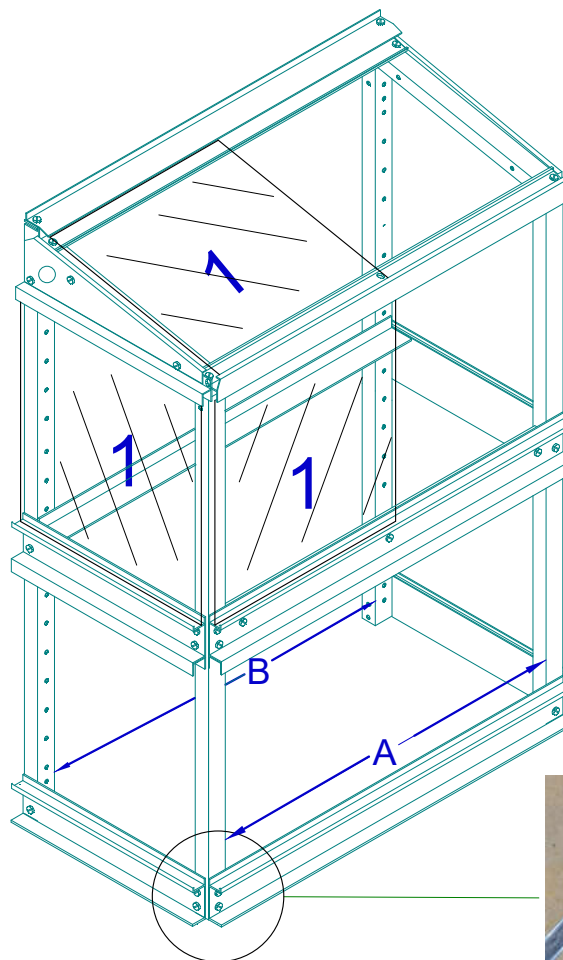

### PARTS NEEDED

Front anchorage pack	FR-AK
Wall fixing pack	FR-WF6

3

### FRONT FIXING TO FLOOR

Once the unit has been fitted to the wall the front anchorage kit (pack FR-AK) can be fitted.

Fit the 'L' bracket to the front leg using a nut and bolt.

Drill through the bracket with a 6mm masonry drill bit, to a depth of 35mm. Insert the red rawplug, through the bracket and into the concrete.

Using woodscrew, screw through the 'L' bracket and into the rawplug.

Repeat for other end.

On BN5 & CN5 models fit an 'L' bracket to the centre leg. Ensure that the front rail is not bowed before fixing.



INSIDE VIEW OF FRONT LEG SHOWING FRONT FIXING

WEAR APPROPRIATE SAFETY EQUIPMENT WHEN DRILLING OR HAMMERING

## FLOOR FALLING AWAY

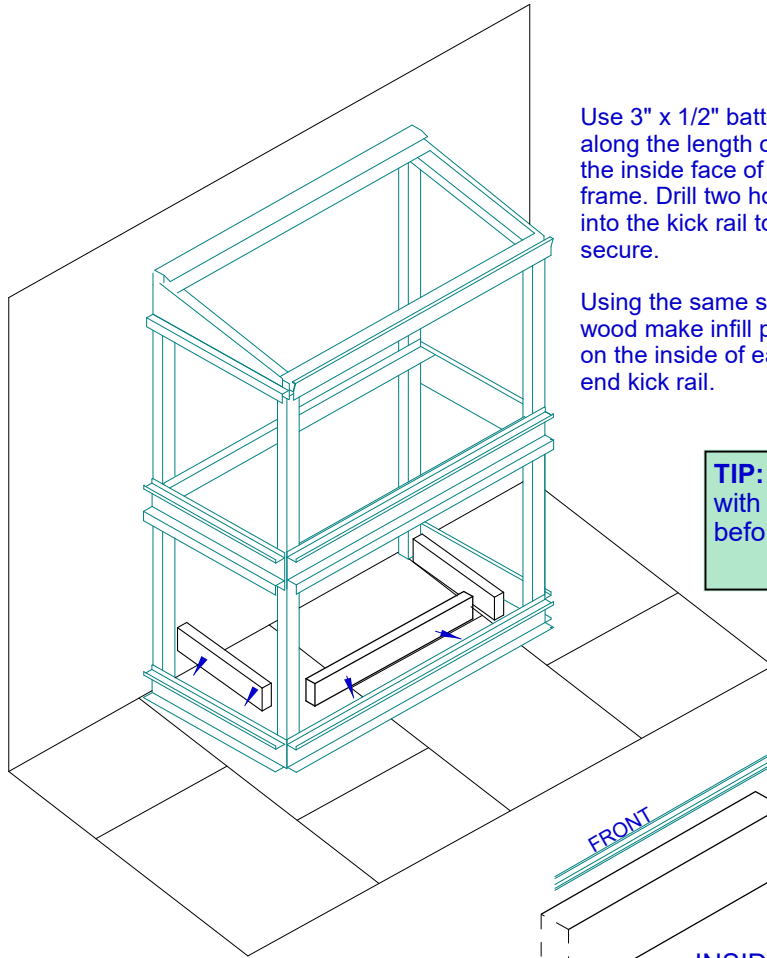

Use 3" x 1/2" batton along the length of the inside face of the frame. Drill two holes into the kick rail to secure.

Using the same size wood make infill pieces on the inside of each end kick rail.

**TIP:** Always treat timber with wood preservative before fixing in place

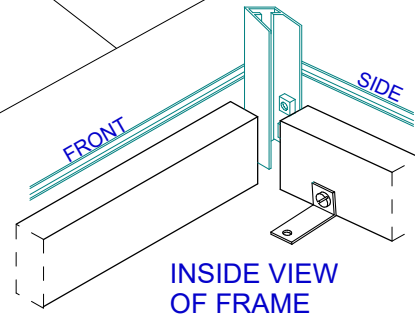

Screw or bolt 'L' shaped brackets to the wood and then to the floor

## ROUGH OR SLOPING WALL

To solve problems with walls choose option A or B below. Fit the frame to the woodwork using 1.25" wood screws. (not supplied)  
Seal around the inside of the frame with silicone sealant when finished.

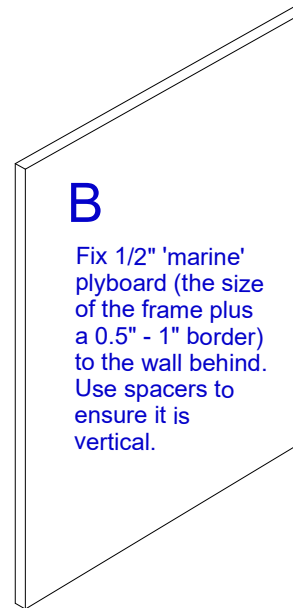

**B**

Fix 1/2" 'marine' plyboard (the size of the frame plus a 0.5" - 1" border) to the wall behind. Use spacers to ensure it is vertical.

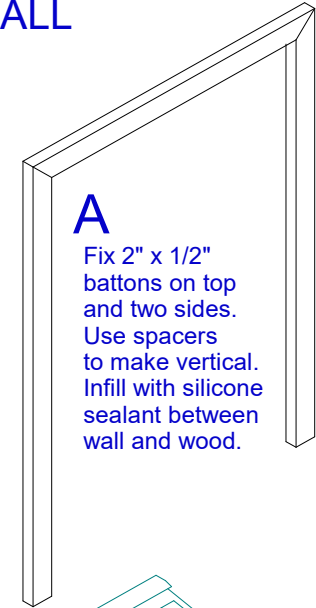

**A**

Fix 2" x 1/2" battons on top and two sides. Use spacers to make vertical. Infill with silicone sealant between wall and wood.

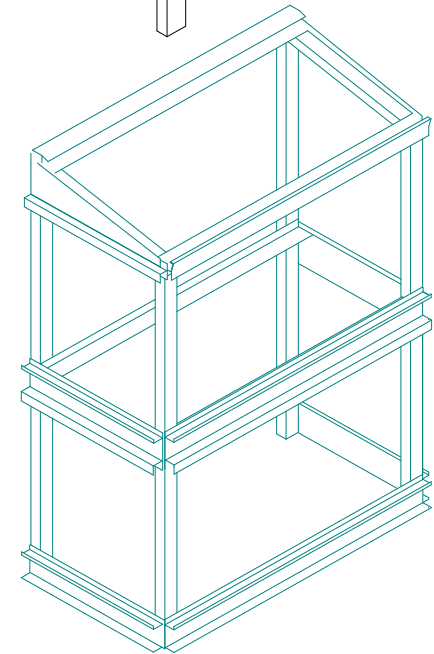



The AN5 model has 5 standard full length shelves.

The BN5 model have 8 standard half length shelves

**1** Lightly tap rawlplug inserts into both ends of the tubular aluminium shelf rods with a hammer.

**2** Screw the support brackets on to each end EXCEPT for the rod that has the support wires.

**3** For the rod with the support wires put the spacer and the support wire onto the screw BEFORE passing through the bracket.



Hook support wire into top hole, then swing shelf upward into the hole. Make sure flat face of shelf

## FITTING

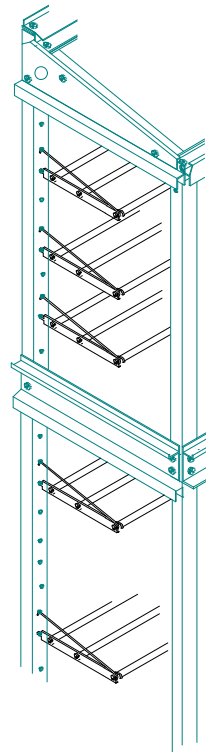
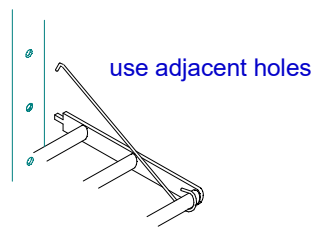

## PARTS NEEDED

Square rod profile  
Flat face is uppermost

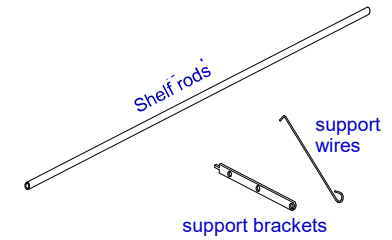
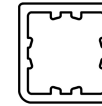

### YOU ALSO NEED PER SHELF ROD:

RAWLPLUG	2
WOOD SCREW	2
Located in packs: S-N2 or S-N1	

### YOU ALSO NEED PER COMPLETE SHELF:

NYLON SPACER	2
Located in packs: S-N2 or S-N1	

The large number of holes in the back leg allow the spacing of the shelves to be easily altered.

When the shelves are not needed they can either be removed or they can be unhooked from the lower fixing hole and hung flat against the back using the wires.



## HALF LENGTH SHELF FITTING

Support wires can share same hole as support bracket



Bottom shelf hung flat against the back

# FITTING THE CHANNEL LINER

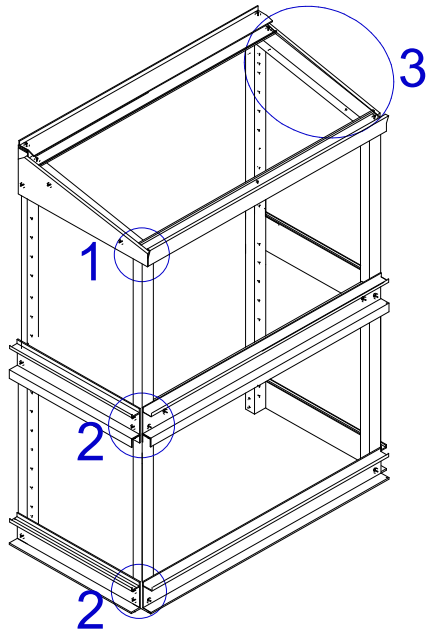

**1** The white liner (W66-2M) fits on the inside vertical face of top FRONT rail only. This is a loose fit so strips of double sided tape are included to secure it until the glass is in place.

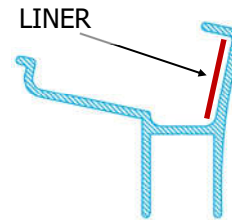
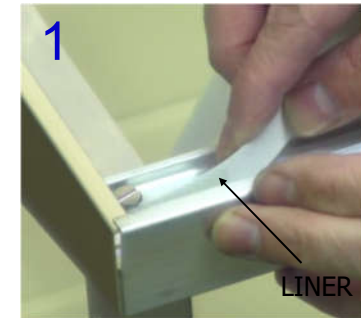

**2** The black plastic liner (W65-5M) goes in the FRONT bottom and centre rails only. Using the strips of double sided tape press liner down so that it LIES FLAT at the bottom of the channel - trim with a knife if necessary.

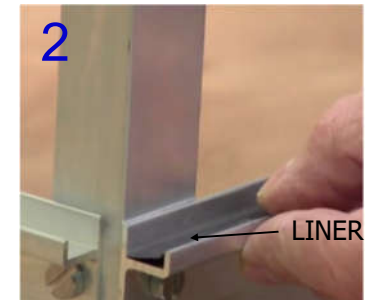

THE DOORS WILL NOT SLIDE PROPERLY IF THE LINER IS NOT FLAT

**3** To make the top glass slide more easily, rub candle wax onto the glass bearers. Also wax the black and white liners.

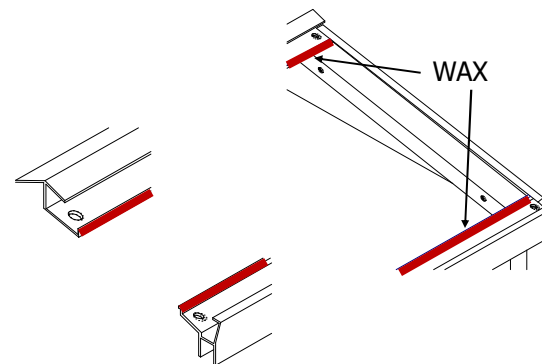

Before sticking the tape, clean the aluminium of any oil traces to promote adhesion.

# FITTING THE HANDLES

When fitting the handles, place the glass on a table or timber battens.  
**NEVER PLACE THE GLASS DIRECTLY ON CONCRETE OR SLABS**

**WARNING**  
 If broken, toughened glass will fragment safely.  
 If the edges are knocked or chipped the glass will spontaneously fragment. This is a natural occurrence due to the toughening process. Care should be taken when moving or cleaning, not to damage the edge of the glass.  
 When placing the glass in the frame, ensure that the glass is securely placed in the runners before letting go of the glass.

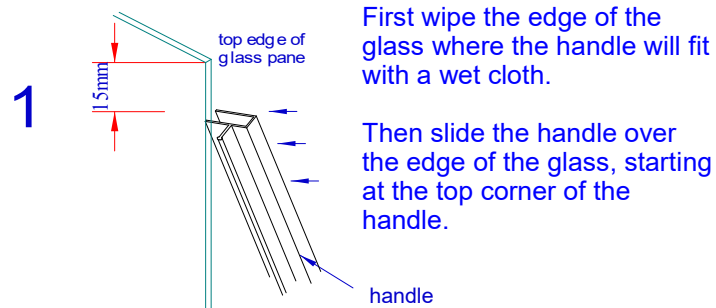

First wipe the edge of the glass where the handle will fit with a wet cloth.

Then slide the handle over the edge of the glass, starting at the top corner of the handle.

**TIP:** Always grip the handle in the CENTRE when sliding

SEE PAGE 11 FOR WHICH GLASS SHEETS NEED HANDLES	'B' sheet
Sheets requiring one handle	2
Sheets requiring two handles	2

**TIP:** Do not try and slide the handle on from the top or bottom

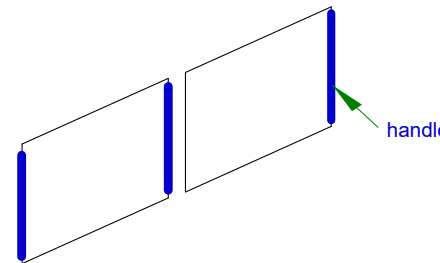

## HANDLES

The right hand glass sheets always have 1 handle.

The left hand glass sheets always have 2 handles.

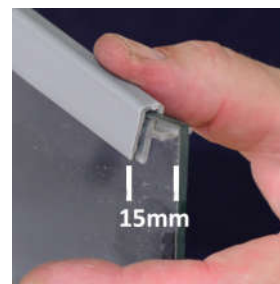
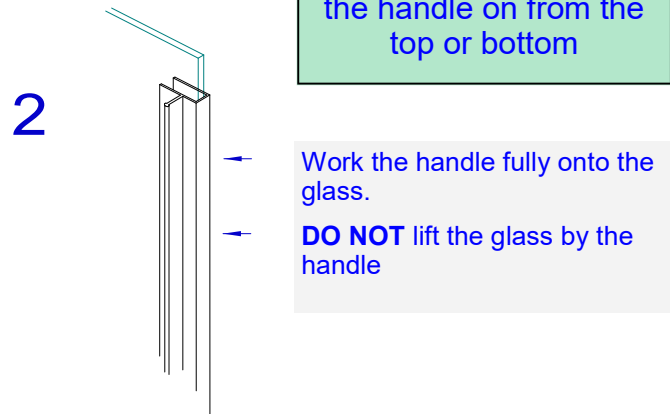

Work on handle from side edge

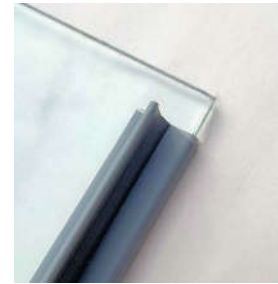

Handle fitted with 15mm gap



Sheet with 2 handles

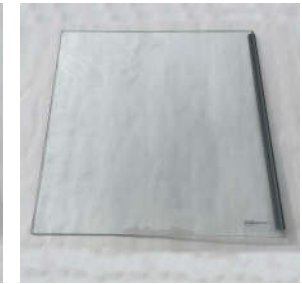

Sheet with 1 handle

### FITTING HANDLES

Fit the handles to the glass before fitting into the frame. Right hand panels always have a single handle on the right hand side of the sheet. Left hand panels have two handles, one on each side.

### FITTING THE GLASS

To fit the glass push the sheet into the deeper top channel, then lower into the bottom channel (A). Make sure the glass is firmly in the bottom channel before letting go. When putting the sheets in the frame, put the first sheet in at the right hand end. The second sheet will fit in front of the first sheet and overlap the first panel by approx. 1" (2cm).

### SLIDING THE FRONT GLASS

When closed, both panels will tuck behind the corner trims to keep them secure. Before sliding the right hand panel open, slide the left hand panel open by approx 1" to release it from behind the corner trim.

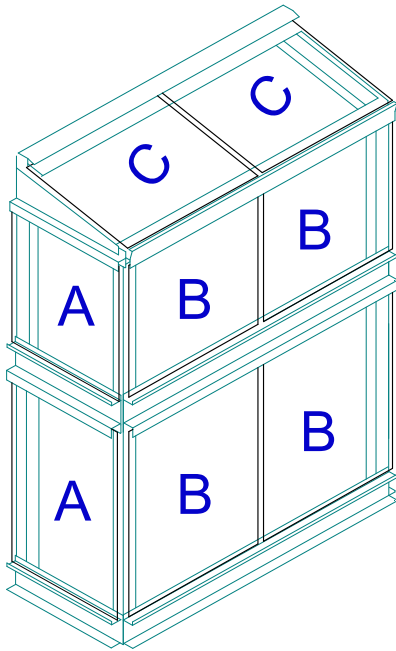

AN5 3'4" Westminster			BN5 5'0" Westminster		
A	298mm x 750mm	Qty: 4	A	298mm x 750mm	Qty: 4
B	750mm x 500mm	Qty: 4	B	750mm x 750mm	Qty: 4
C	298mm x 500mm	Qty: 2	C	298mm x 750mm	Qty: 2
Top and end glass (A & C) have no handles					



A. Fitting the glass



Glass in channel with two sheets overlapping



Roof glass overlapping

## BLACK 'WEDGES'

The small black thimble wedges (w) are designed to be pushed into the top channels of the end glass to stop the glass moving. Use two wedges per sheet of glass



Located in pack: SCREW-P1



Corner trim in place

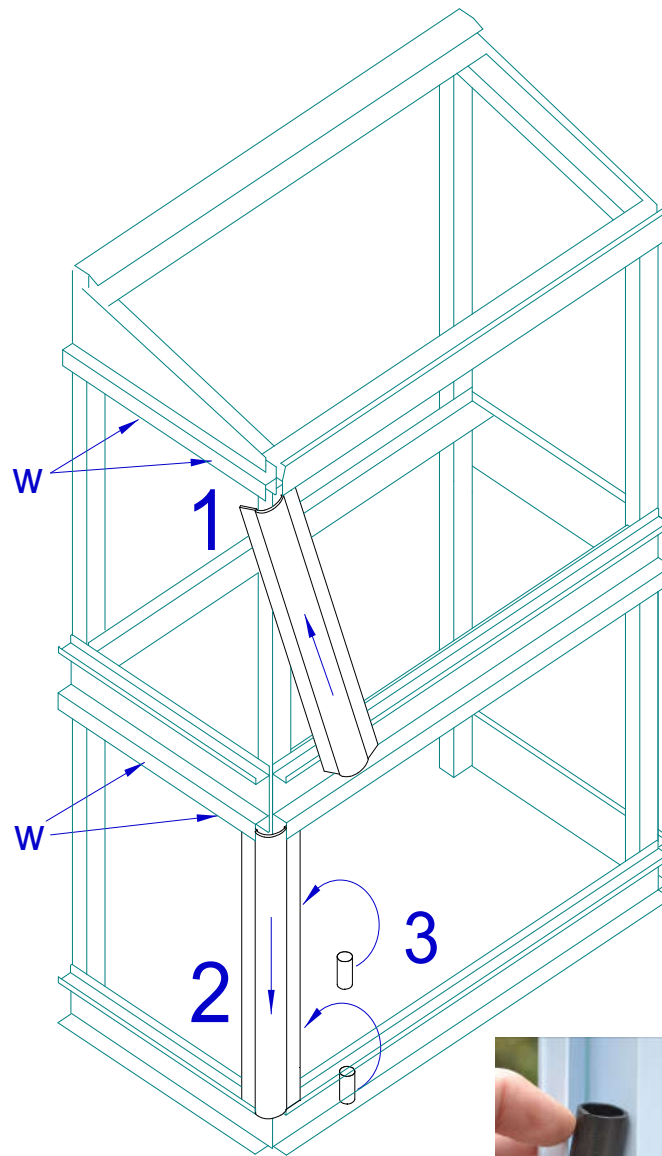

Fitting the hollow tube

## Aluminium corner trims

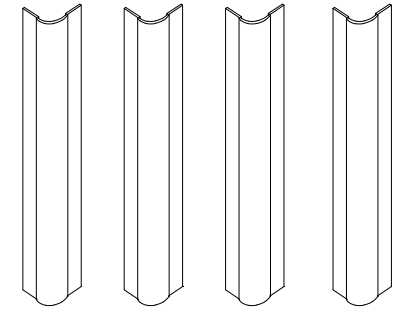

You also need:  
2 bags marked as TRIM-4

## PARTS NEEDED



- 1 Take one of the corner trims and push it up into the top channel and the 'h' section.
- 2 Swing the corner trim in so that it is vertical and drop it into the channel below. At this point the trim will be loose.
- 3 Slide the front glass door out of the way. Take one of the hollow tubes contained in the pack marked 'TRIM'. From the front of the frame, push the tube between the framework and the corner trim. Slide the tube downwards as far as it will go.  
  
Insert a second hollow tube and repeat the action, but this time push the tube up as far as it will go.  
  
These tubes keep the corner trim firmly in place, and act as a stop for the sliding doors.
- 4 Repeat for the other 3 corners



<b>CORNER TRIMS WILL NOT FIT</b>	The most common cause of this problem is the end glass protruding over the front leg. This is normally caused because the frame work is not square against the wall. See page 6.
<b>GLASS STICKS TOGETHER</b>	<p>This is normally due to the handles not being put on the right side of the glass. See page 10 for details of where the handles should be fitted to the glass.</p> <p>If the glass has stuck together, push the two sheets to the back of the channel, then slowly pull the front sheet of glass forward from one end. This will release the suction between the sheets.</p>
<b>HANDLES COME OFF</b>	<p>As the handles are of a clamp design they can be pulled off if too much force is applied to them. If the glass has stuck together due to moisture, or if the glass does not slide smoothly, this will strain the clip part of the handle and cause it to come off.</p> <p>Ensure that the channels and the glass are kept clean at all times to minimise the sliding force needed. Candle wax applied to the channel and the underside of the glass will also help the sliding action. Also check that the handles have been fitted correctly. See page 10 for full instructions.</p> <p>Handles can be rejuvenated by placing them in hot water, cleaning them carefully, then squeezing the clip together while the plastic is still warm. Leave to cool before fitting.</p> <p>If handles come off frequently either purchase some new handles from Access or use a glue such as 'liquid nails' or 'no more nails' to permanently glue the handles to the glass.</p>
<b>SHELVES WILL NOT FIT INTO THE BACK LEGS</b>	<p>Check that the back legs have been fitted the right way round - see page 2.</p> <p>Check that dimension A = B - see page 6.</p>
<b>GLASS FALLS OUT OF THE LOWER LEVEL</b>	Ensure that the centre rail has the deeper channel at the bottom.



## **PERIODIC MAINTENANCE**

Every Spring take the glass out of the greenhouse and wash glass and framework with warm soapy water.

Lubricate the automatic louvre vent bi-monthly and remove if subject to very heavy frosts.

When inserting the glass, always check that the glass is properly seated in its top and bottom channels before letting go of the sheet.

**CHECK THE TIGHTNESS** of all bolts regularly, especially in very windy areas or powder coated frames.

**CROP ROTATION** Suggestions for suitable crops and sowing dates given in the free Access Growing Guide.

**VENTILATION** In cold weather gentle ventilation can be given by sliding the four front sheets of glass to give 2-3" (5-8cm) gap at each corner.

In warmer weather allow a gap on the top sheets as well. In very hot weather open all the sheets of glass.

To ensure that the correct temperature is maintained use a thermometer inside the greenhouse. You can completely remove the top sheets in summer. Access shading will help keep temperatures down, and stop birds etc getting inside.

**GALES** The greenhouse must be kept fully closed in rough weather.

**GLASS CHANNELS** Ensure that this is kept free from debris and allows the glass to slide smoothly. Periodically lubricate the running edge of the glass with a wax candle.

**SNOW** If snow is very heavy - avoid letting it build up on the roof

**SHELVING** Stand pot plants on saucers, or use optional shelf covers which incorporate a layer of capillary matting to absorb excess water when watering. Alternatively, stand the pots in empty seed trays.

**SITING** Site on the sunniest place available. Anything from East through South to West is suitable. If it has to face North, don't despair, it will be warmer in than outside! If you can fix to a brick or stone wall, you will get extra heat storage during the day.

**REDUCING THE LENGTH** If it is just too long for your ideal spot, it can be shortened. Re-drill the holes at one end of the rails - moving them in by the amount you need to remove. Hacksaw off the surplus aluminium and shorten the shelf rods. The glass will merely overlap more - don't try to cut toughened glass!