

# ASSEMBLY INSTRUCTIONS

## Herb House

### CONTENTS

Main aluminium parts	P1
End sections	P2
Adding the long rails	P3
Centre & lower back rails	P4
Staging rails	P5
End plates	P6
Squaring & fixing	P7
Top back infill panel	P8
Shelving	P9
Watering (optional)	P10
Fitting liner	P11
Fitting the slatted base	P12
Fitting handles	P13
Fitting the glass	P14
Fitting corner angles	P15
Troubleshooting	P16
Notes on using the frame	P17



### Video instructions:

Helpful video clips are available at

[www.garden-products.co.uk/instructions](http://www.garden-products.co.uk/instructions)

### Can we improve?

We hope that you find our instructions clear and concise. If you have any suggestions for improvements email:

[instructionfeedback@garden-products.co.uk](mailto:instructionfeedback@garden-products.co.uk)

Please keep all packaging until installation is complete

Access Garden Products  
Crick  
NORTHAMPTON  
NN6 7XS

Tel: 01788 822301  
Fax: 01788 824256  
[sales@garden-products.co.uk](mailto:sales@garden-products.co.uk)  
[www.garden-products.co.uk](http://www.garden-products.co.uk)

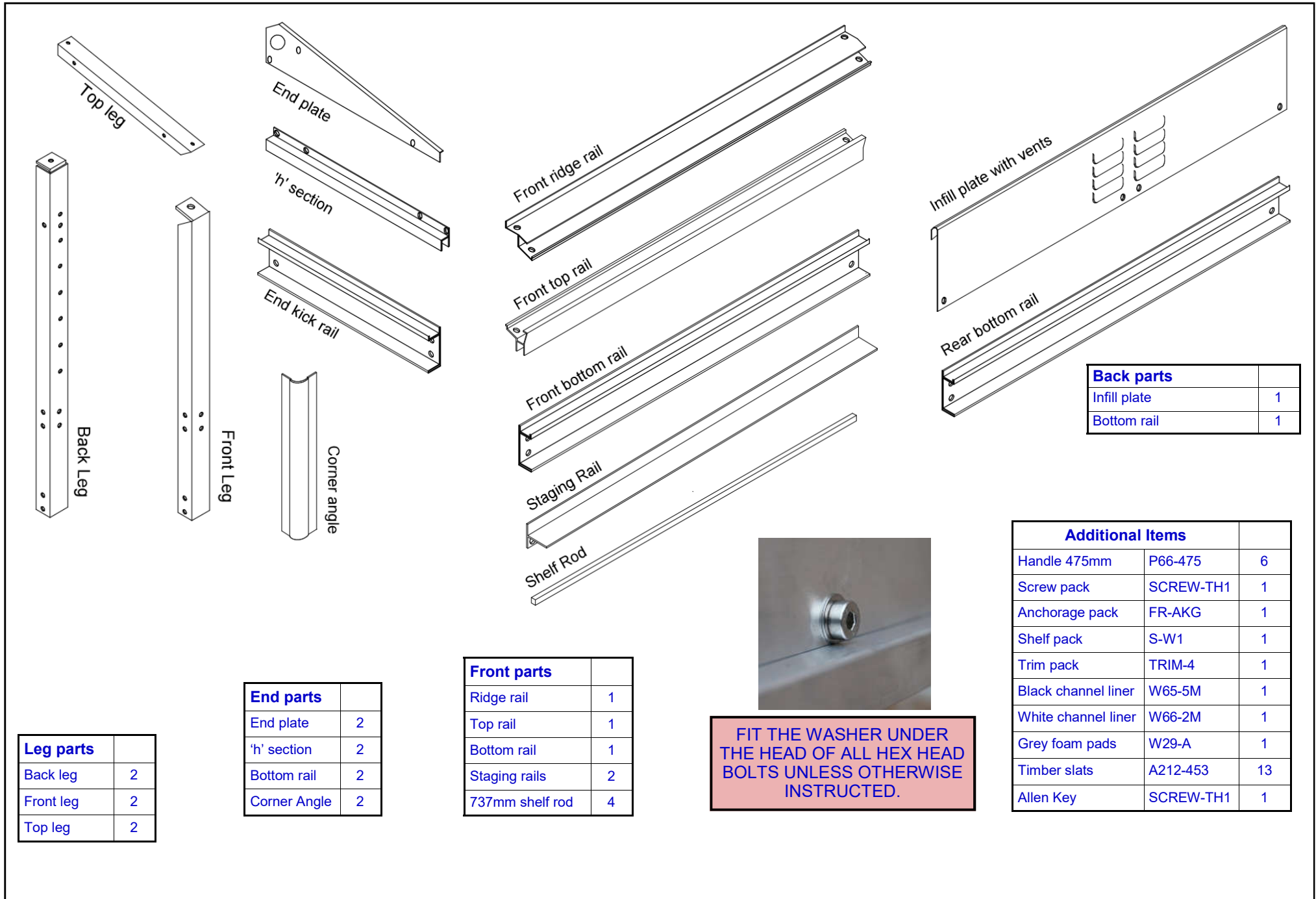

Back parts		
Infill plate		1
Bottom rail		1

Additional Items		
Handle 475mm	P66-475	6
Screw pack	SCREW-TH1	1
Anchorage pack	FR-AKG	1
Shelf pack	S-W1	1
Trim pack	TRIM-4	1
Black channel liner	W65-5M	1
White channel liner	W66-2M	1
Grey foam pads	W29-A	1
Timber slats	A212-453	13
Allen Key	SCREW-TH1	1



**FIT THE WASHER UNDER THE HEAD OF ALL HEX HEAD BOLTS UNLESS OTHERWISE INSTRUCTED.**

End parts		
End plate		2
'h' section		2
Bottom rail		2
Corner Angle		2

Front parts		
Ridge rail		1
Top rail		1
Bottom rail		1
Staging rails		2
737mm shelf rod		4

Leg parts		
Back leg		2
Front leg		2
Top leg		2



Top leg rests against the **FLAT FACE** of back leg - it is not bolted to the back leg



Slide the tongue of the front leg into the groove on the top leg.

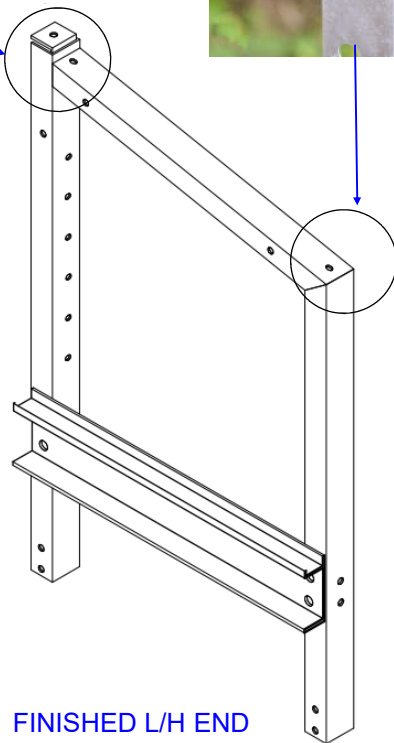

FINISHED L/H END

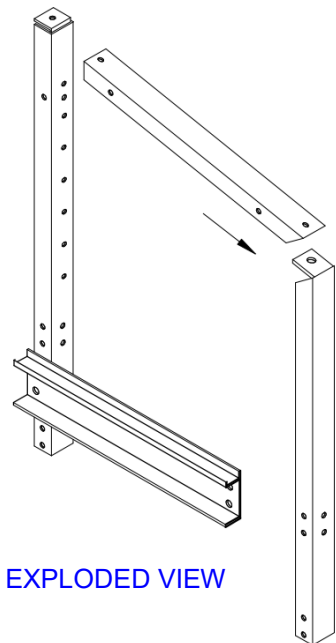

EXPLODED VIEW

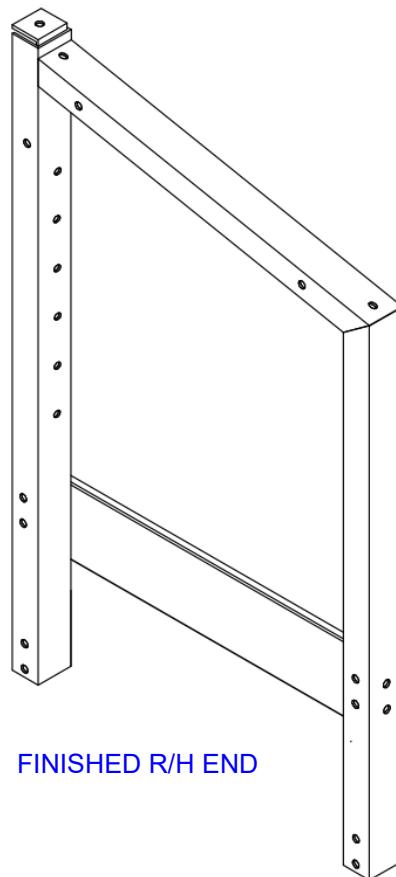

FINISHED R/H END

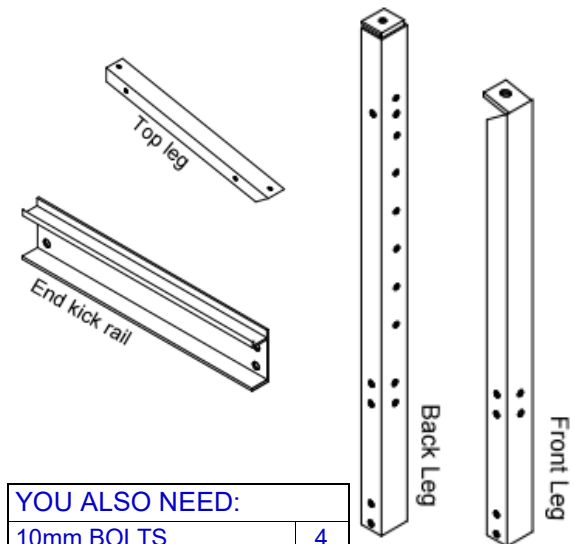

**YOU ALSO NEED:**

10mm BOLTS	4
METAL WASHERS	4
NUTS	4
Located in pack: SCREW-TH1	

**PARTS NEEDED FOR EACH END**

- 1 Make up the LEFT hand end as shown.
- 2 Make up the RIGHT hand end as shown

**DO NOT FULLY TIGHTEN BOLTS AT THIS STAGE**

**END SECTIONS**



FIXING DETAIL

DO NOT FIT A WASHER AT THE 4 POINTS MARKED X  
IF POWDERCOATED, TAKE CARE NOT TO OVERTIGHTEN BOLTS AS IT WILL DAMAGE THE COATING

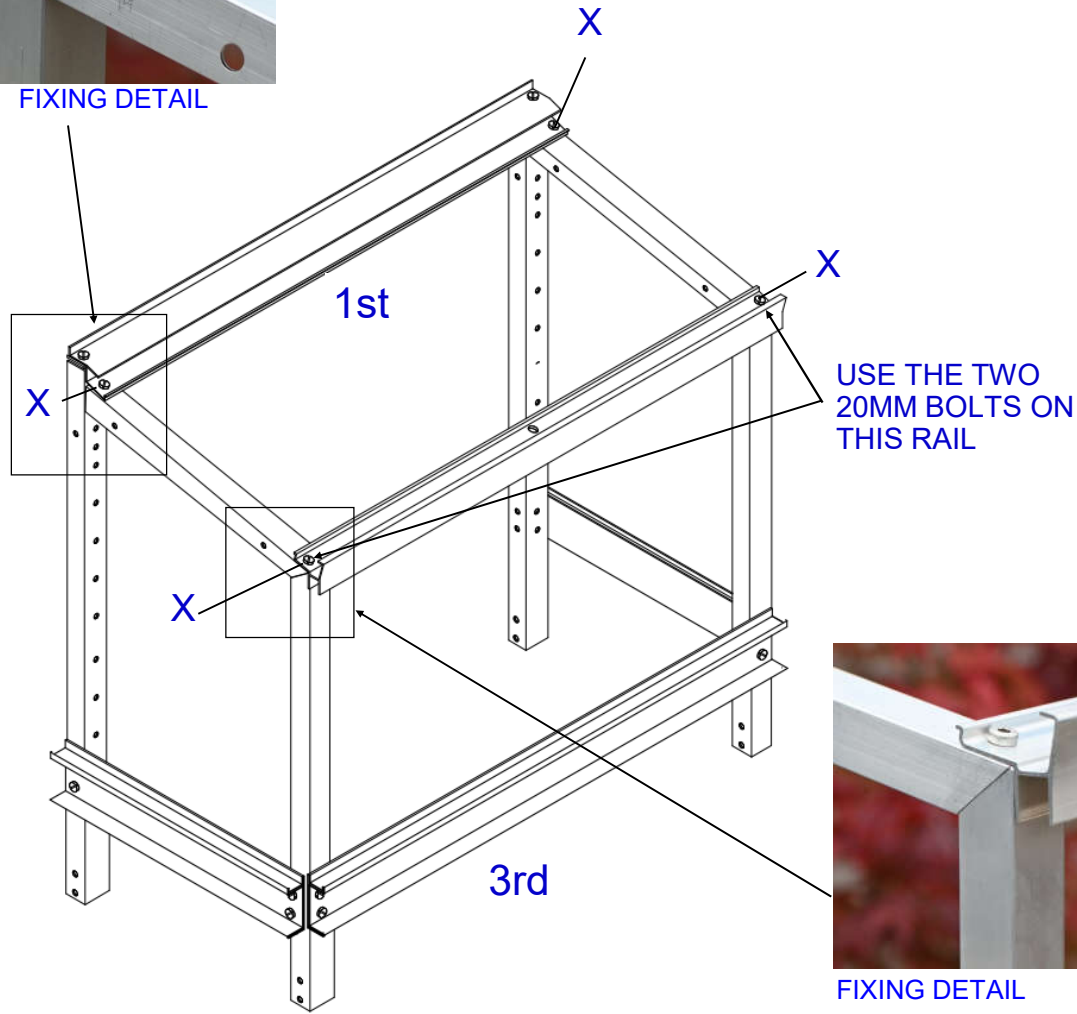

## PARTS NEEDED

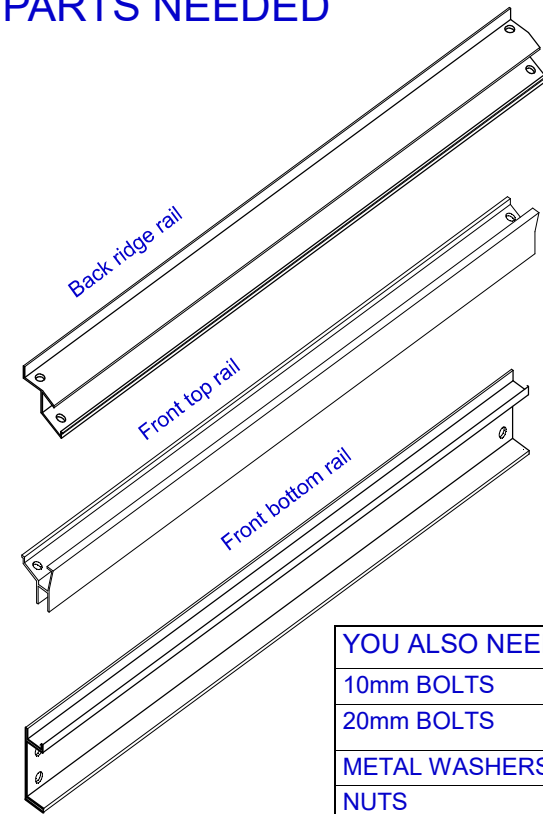

YOU ALSO NEED:	
10mm BOLTS	6
20mm BOLTS	2
METAL WASHERS	4
NUTS	8
Located in pack: SCREW-TH1	

- 1 Bolt on the rails in the order shown. On 3rd rail (front bottom rail) only bolt through the lower two holes. Leave the upper two holes unbolted at this stage.



FIXING DETAIL

DO NOT FULLY TIGHTEN BOLTS AT THIS STAGE

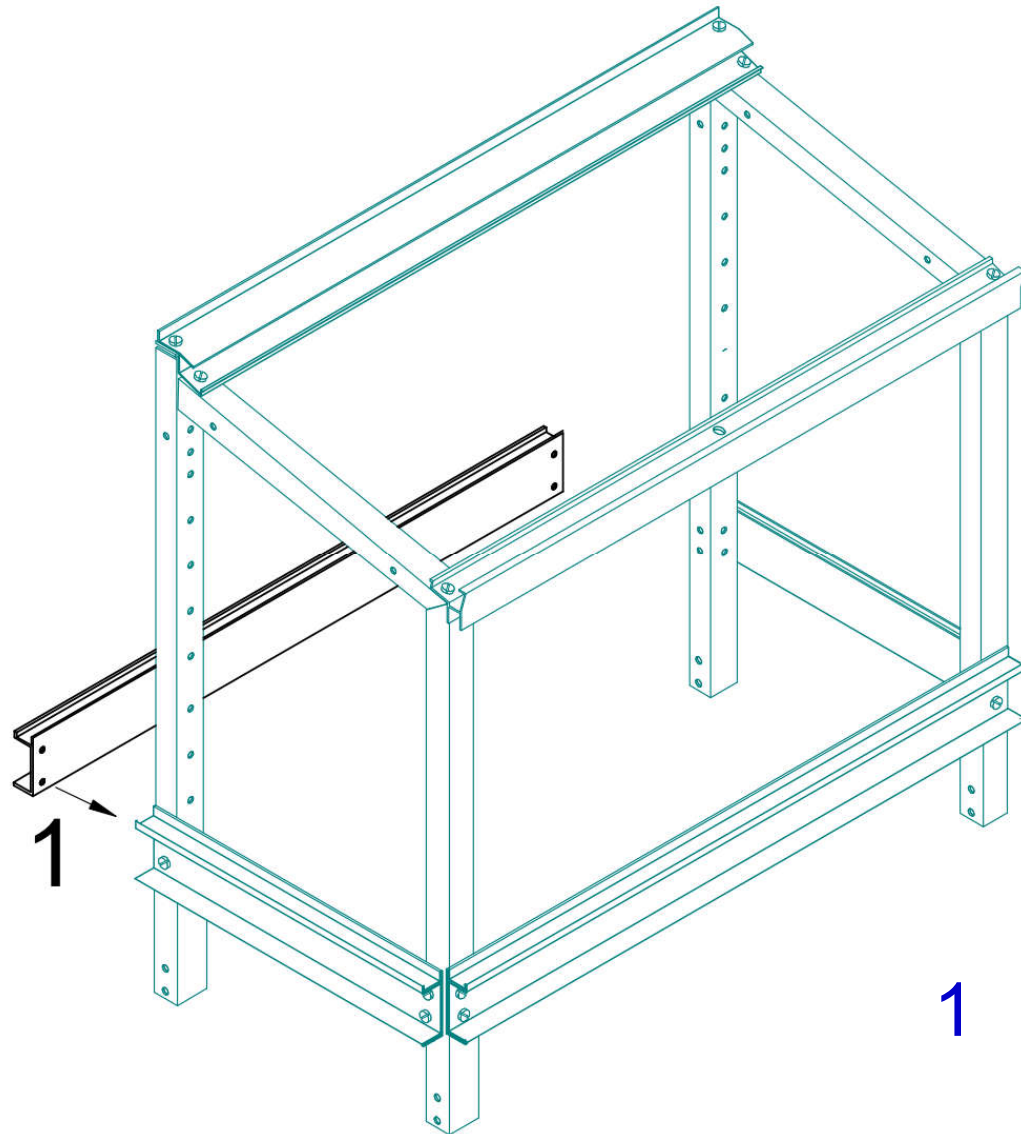

## PARTS NEEDED

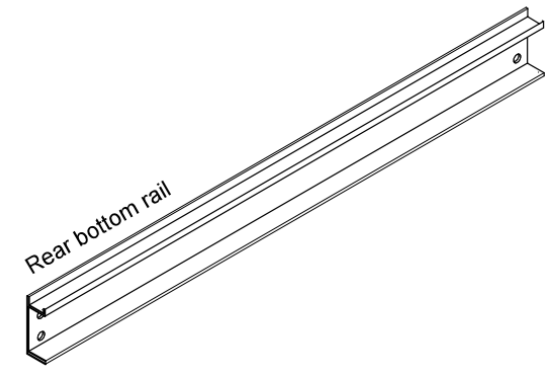

### PARTS ALSO NEEDED

40mm BOLTS	2
METAL WASHERS	2
NUTS	2
20mm NYLON SPACERS	2
Located in pack: SCREW-TH1	

1

**Rear bottom rail:** Put a metal washer on the bolt and push the 40mm bolt through the lower hole of the bottom rail. Push a 20mm nylon spacer on to the bolt BEFORE passing the bolt through the back leg and **loosely** fit a nut. Repeat on the lower hole at the other end.

Leave upper holes for the staging rail - see P5



Nylon spacer on bolt

**DO NOT FULLY TIGHTEN BOLTS AT THIS STAGE**

## REAR BOTTOM RAIL

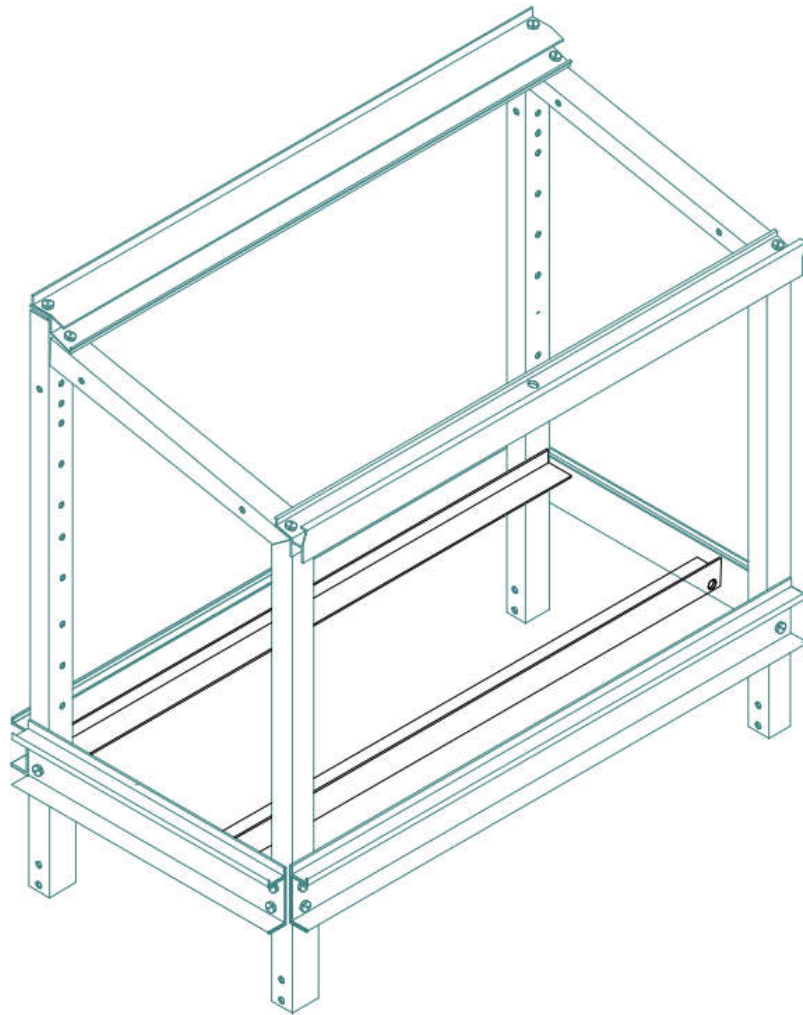

Staging rails must have fixing bolt holes on the underside



## PARTS NEEDED

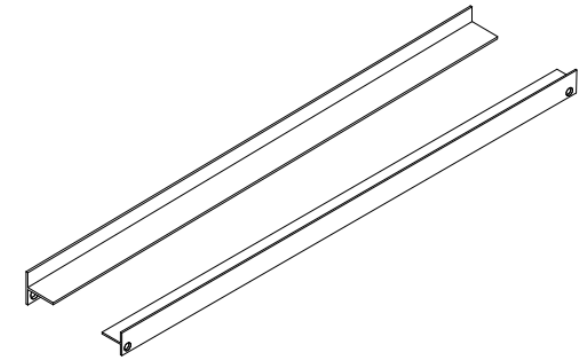

### YOU ALSO NEED:

40mm BOLTS	4
METAL WASHERS	4
20mm NYLON SPACERS	4
NUTS	4
In pack: W29-A	

## 1 POSITION THE RAILS INSIDE THE FRAME AS SHOWN. BOLT THROUGH HOLES SHOWN

**Front rail:** Put a metal washer on the bolt and push the 40mm bolt through the bottom rail **upper** holes. Slide on nylon spacers, then the front staging rail before fitting the nuts.

**Back rail:** Put a metal washer on the bolt and push the 40mm bolt through the bottom rail **upper** holes. Push 20mm nylon spacer onto the bolt before passing the bolt through the back leg. Fit the support onto the bolt then fit a nut.

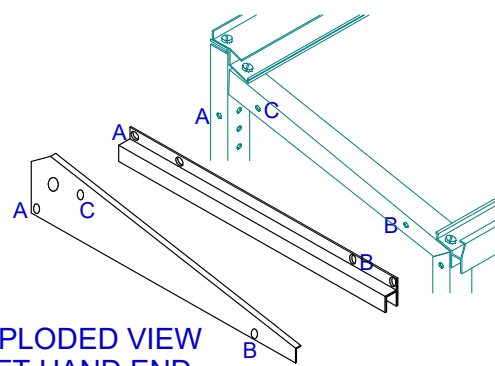

EXPLODED VIEW  
LEFT HAND END

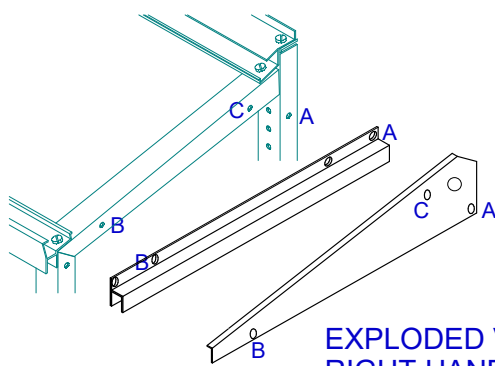

EXPLODED VIEW  
RIGHT HAND END

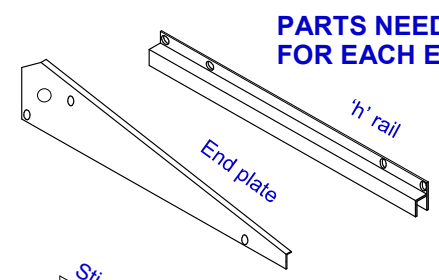

**PARTS NEEDED  
FOR EACH END**

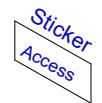

**YOU ALSO NEED:**

10mm BOLTS	3
METAL WASHERS	3
NUTS	3
Located in pack: SCREW-TH1	



THE END PLATE  
FITS UNDER THE  
RIDGE RAIL LIP

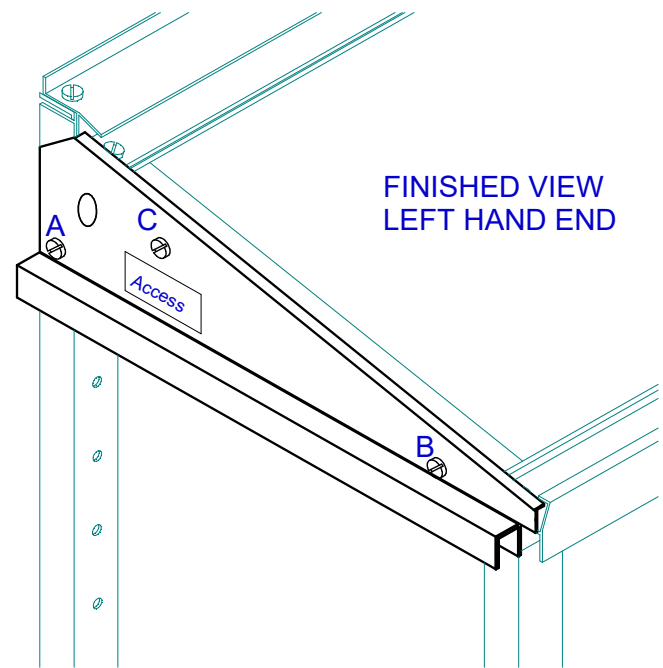

FINISHED VIEW  
LEFT HAND END



THE END PLATE  
FITS UNDER THE  
FRONT RAIL LIP

- 1 **Remove any plastic protective film** from the end plates and put 'Access' sticker on.
- 2 Make up the LEFT hand end as shown.
- 3 Make up the RIGHT hand end as shown.

**NB** Bolt 'C' only goes through the end plate and the frame.

**DO NOT FULLY TIGHTEN BOLTS AT THIS STAGE**

# 1 SQUARING THE FRAME

Use a metal set square or an A4 piece of card to square the unit up as shown. Slacken the bolts if necessary to move the framework into a square position.

Once the frame is completely square tighten up all the bolts.

**FULLY TIGHTEN ALL BOLTS**

**PARTS NEEDED**  
Front anchorage pack FR-AKG

IF THE HERB HOUSE IS IN A VERY WINDY LOCATION WE RECOMMEND BOLTING TO THE GROUND.  
WEAR APPROPRIATE SAFETY EQUIPMENT WHEN DRILLING OR HAMMERING

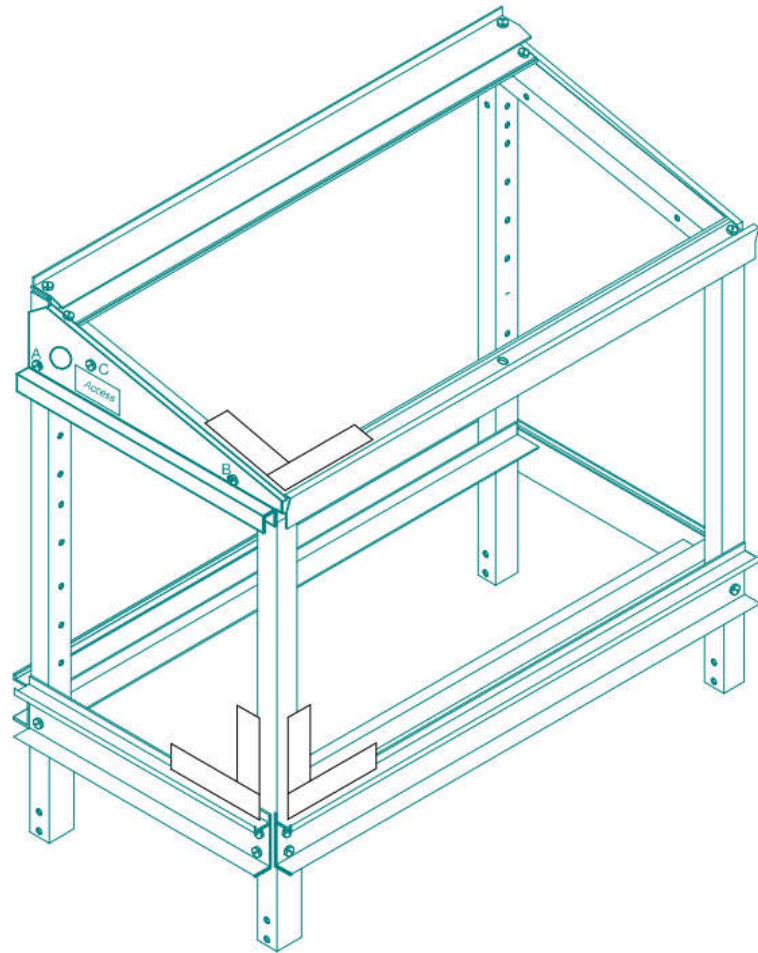

# 2 FIXING TO THE FLOOR

Carefully lay the frame on it's front and fit the 'L' brackets to the legs using a nut and bolt.

Place the framework in its final position and mark the hole positions. Remove the frame and drill through the bracket with a 6mm masonry drill bit, to a depth of 35mm. Insert the red rawlplug, through the bracket and into the concrete.

Reposition the frame and using a woodscrew, screw through the 'L' bracket and into the rawlplug.

Repeat for other brackets.

**TIP:** If the frame needs to be fixed close to a wall or fence, fit the infill panel (page 8) before fixing down.

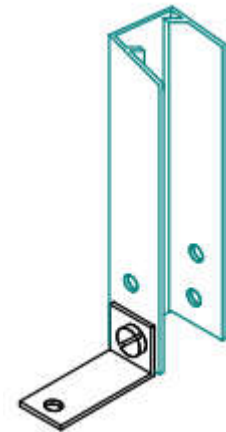

Completed bracket



**1** Remove the plastic protective film from the infill plate and end glass bracket. Put a metal washer on the 10mm bolt which goes through the infill plate from the **outside** at hole 'E'. Put a 3mm white spacer on each bolt before pushing on the glass bracket, then fit the nut. Glass bracket is **INSIDE** frame and will clamp onto the glass once the glass is in place.



Completed bracket **inside** Growhouse



White spacers on infill plate

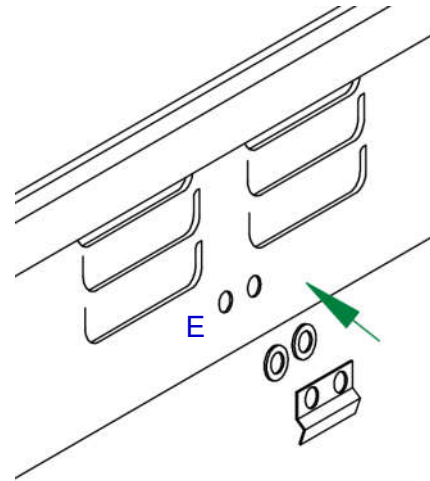
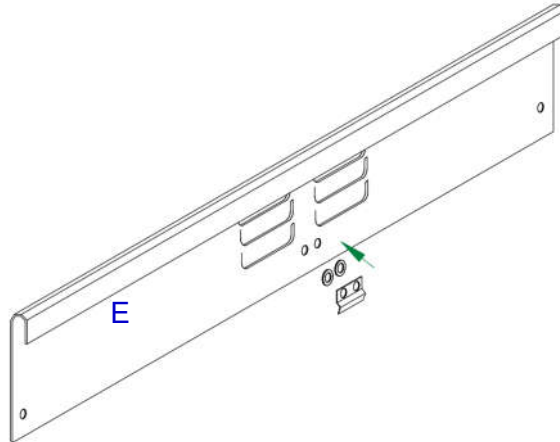

Infill plate fitted

**2** Place the lipped section over the upstand on the back rail. Push a long 40mm bolt and metal washer through hole A, then fit a white 3mm spacer and a 20mm nylon spacer. Push the bolt into the frame and fit a nut on the inside of the frame.

Repeat for hole B at the other end.

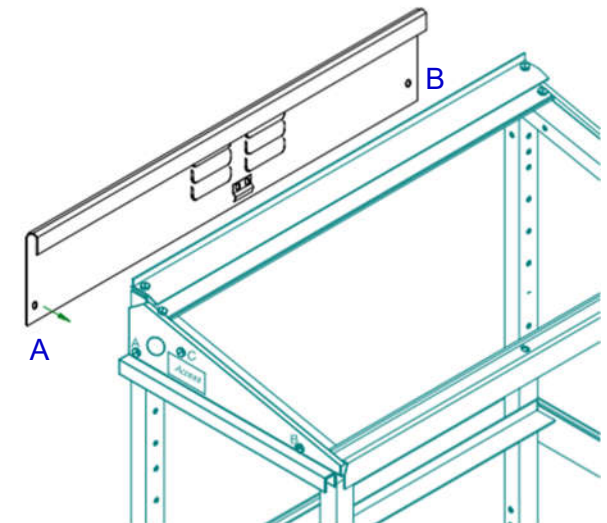

## PARTS NEEDED

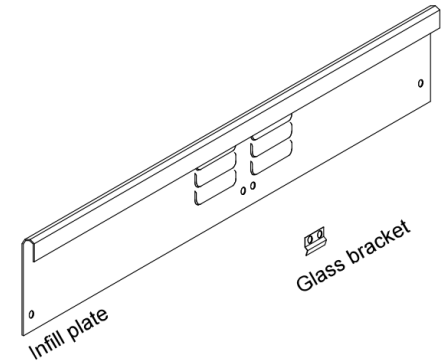

### PARTS ALSO NEEDED

10mm BOLTS	2
40mm BOLTS	2
METAL WASHERS	4
NUTS	4
20mm WHITE SPACERS	2
3mm WHITE SPACERS	4
Located in pack: SCREW-TH1	

The TH1 model has 1 wide full length shelf.

- 1 Lightly tap rawlplug inserts into both ends of the tubular aluminium shelf rods with a hammer.
- 2 Screw the support brackets on to each end EXCEPT for the rod that has the support wires.
- 3 For the rod with the support wires put the spacer and the support wire onto the screw BEFORE passing through the bracket.

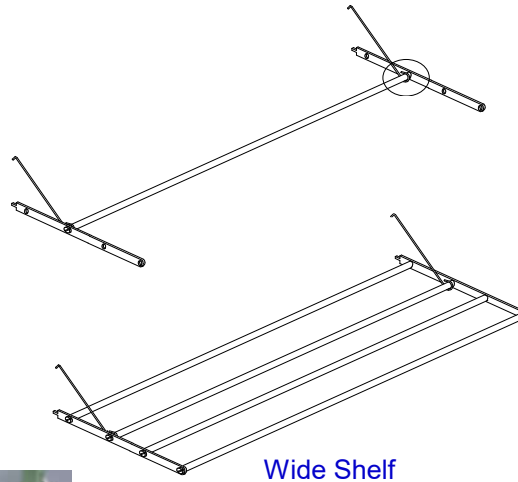

Wide Shelf

### PARTS NEEDED

Square rod profile  
Flat face is uppermost

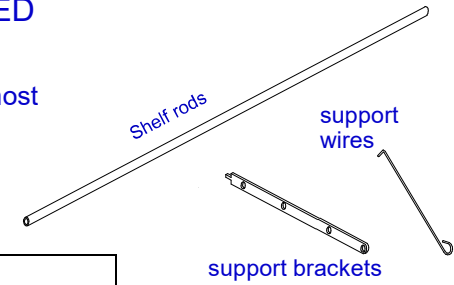
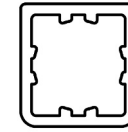

YOU ALSO NEED  
PER SHELF ROD:

RAWLPLUGS	2
WOOD SCREW	2
Located in packs: S-W1	

YOU ALSO NEED  
PER COMPLETE SHELF:

NYLON SPACER	2
Located in packs: S-W1	



#### 5-hole strap

Fit the rods to the holes 'F' - the rod with support wire is marked SW. The centre hole is unused.

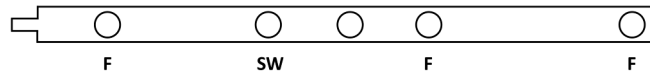

### FITTING

Hook support wire into the top hole, then swing shelf upward into the next but one hole.

Make sure flat face of shelf rod is uppermost.

The large number of holes in the back leg allow the spacing of the shelf to be easily altered.

When the shelf is not needed it can either be removed or it can be unhooked from the lower fixing hole and hung flat against the back using the wires.



Shelf hung flat against the back

Note: A Pozidrive screwdriver will fit the screws best

1 Choose which end you would like the watering inlet.



Fit the washer onto the thread of the adaptor, and then fit the nipple

Push the assembly through the hole from the inside

Screw the brass elbow onto the protruding thread from the outside

**TIP:** Dip the end of the grey pipe in water. For a better fit, twist the pipes as they are inserted.

3 Fit the irrigation system as shown. The grey tubes push into the black fittings. Ensure the open face of the grey nozzle faces into the frame.

2 'L' shape brackets need to be fitted inside the frame. x - Use a nut and bolt to fix to the hole

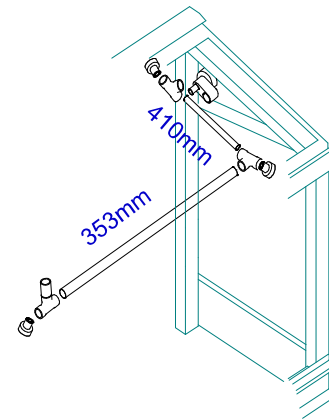
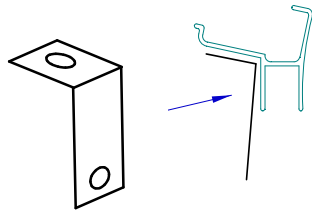
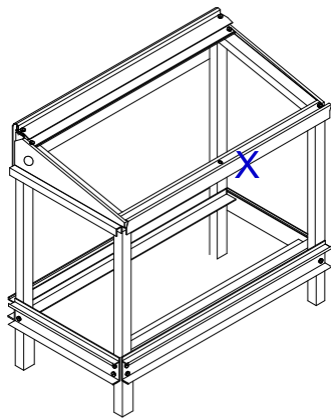

4 Fit the black grommet (from pack SCREW-TH1) into the unused irrigation hole at the opposite end of the unit.

Once assembled use the black straps to secure the watering system to the 'L' shaped brackets and then strap the pipes to the end of the frame using the hole in the top leg.



Blanking grommet



Inlet and link pipe



Nozzle strapped to 'L' bracket

PARTS NEEDED:	
NOZZLE ASSEMBLY	1
SINGLE TEE	2
BLANKING PLUG	3
'L' BRACKET	1
GREY PIPES	2
ENTRY FITTING: Nipple, adaptor, washer and brass elbow	1
10MM BOLTS & NUTS	1
BLACK STRAPS	3
Located in pack: I-SP-1	

IF YOU DID NOT PURCHASE THE WATERING SYSTEM, FIT A BLANKING GROMMET AT BOTH ENDS

# FITTING THE CHANNEL LINER

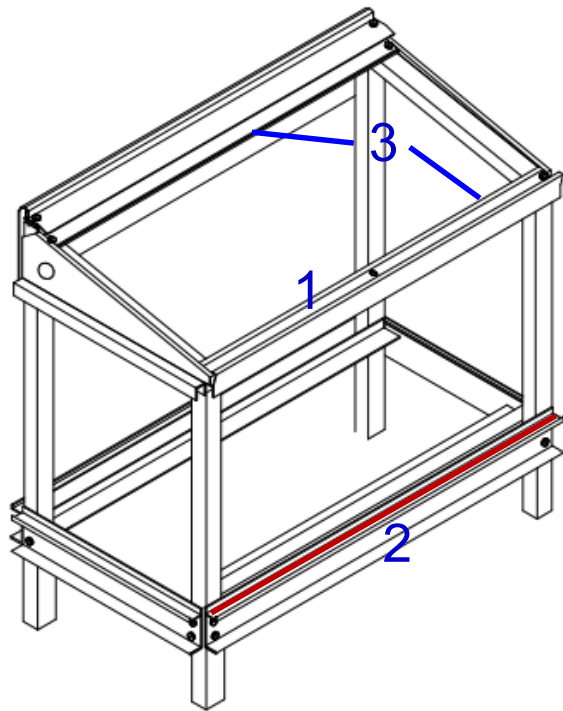

Before sticking the tape, clean the aluminium of any oil traces to promote adhesion.

**1** The white liner (W66-2M) fits on the inside vertical face of top FRONT rail only. This is a loose fit so strips of double sided tape are included to secure it until the glass is in place.

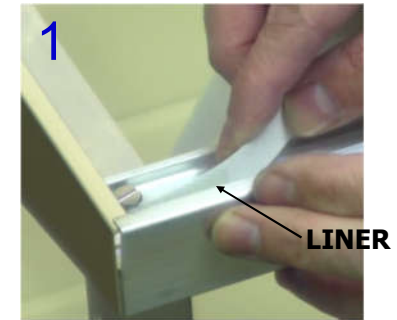
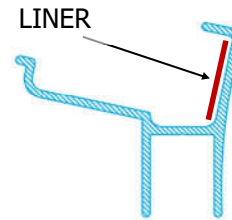

**2** The black plastic liner (W65-5M) goes in the FRONT rail only. Using the strips of double sided tape press liner down so that it LIES FLAT at the bottom of the channel - trim with a knife if necessary.

THE DOORS WILL NOT SLIDE PROPERLY IF THE LINER IS NOT FLAT

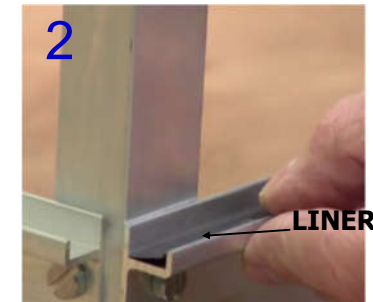

**3** To make the top glass slide more easily, rub candle wax onto the glass bearers. Also wax the black and white liners.

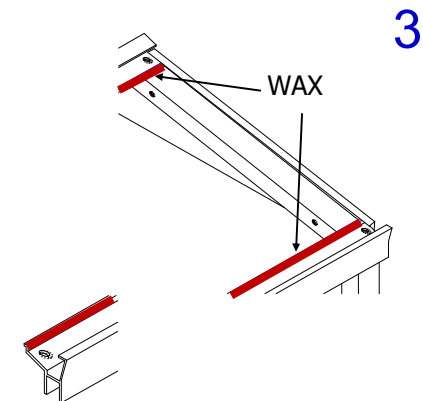
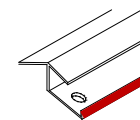

## FITTING THE SLATS

### PARTS NEEDED

13 wooden slats 453mm long  
W29-A Pack of grey foam pads

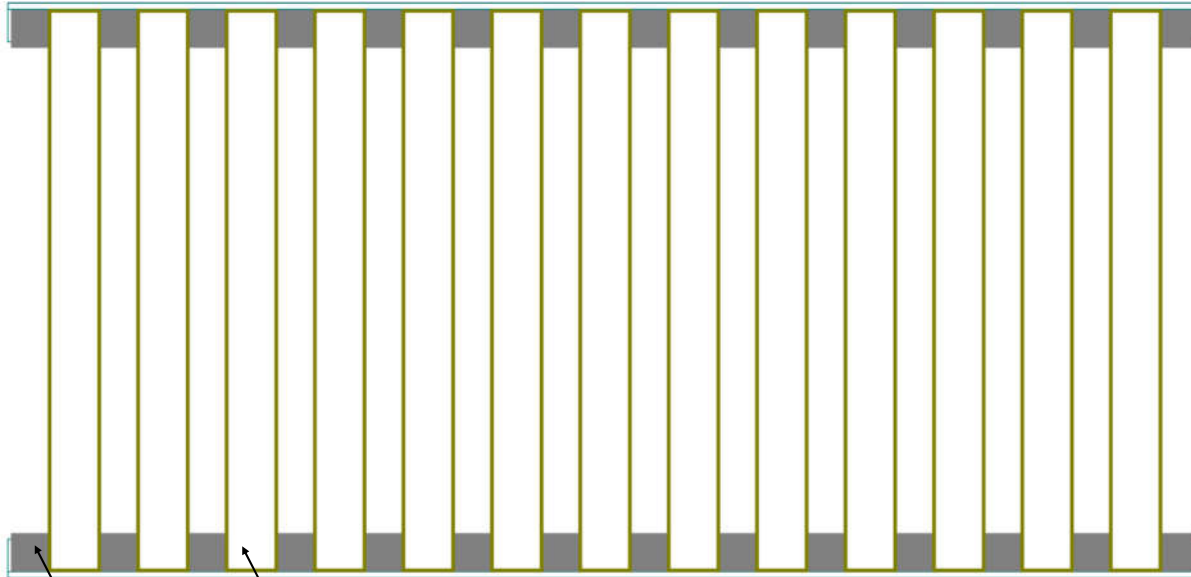

GREY  
PAD

WOODEN  
SLAT

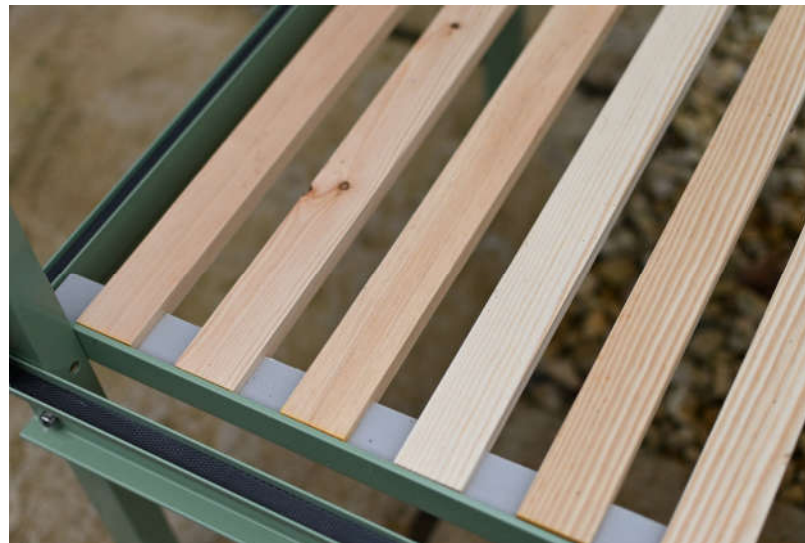

1

Wipe the top surface of the front and rear staging rails to remove any dirt or grease. Allow to fully dry.

2

Starting at one end, place a square grey foam pad on the front and back rail. These will protrude over the rail by a few mm

3

Place a wooden slat on the staging rails, touching the front and rear pad. The place pads on the other side of the slat, leaving no gap.

4

Repeat across the width of the frame. 13 slats are needed in total.

# FITTING THE HANDLES

When fitting the handles, place the glass on a table or timber battens.  
**NEVER PLACE THE GLASS DIRECTLY ON CONCRETE OR SLABS**

**WARNING**  
 If broken, toughened glass will fragment safely.  
 If the edges are knocked or chipped the glass will spontaneously fragment. This is a natural occurrence due to the toughening process. Care should be taken when moving or cleaning, not to damage the edge of the glass.  
 When placing the glass in the frame, ensure that the glass is securely placed in the runners before letting go of the glass.

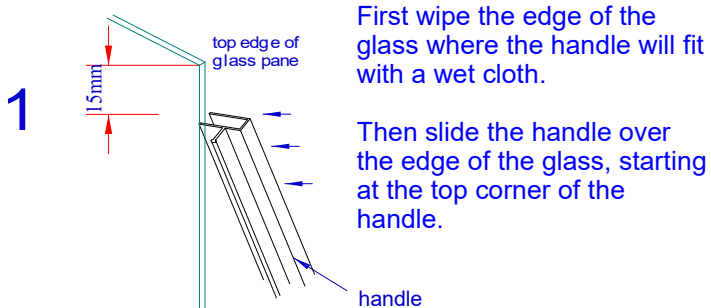

**TIP:** Always grip the handle in the **CENTRE** when sliding

SEE PAGE 13 FOR WHICH GLASS SHEETS NEED HANDLES	'B' sheet	'C' sheet
Sheets requiring one handle	1	1
Sheets requiring two handles	1	1

**TIP:** Do not try and slide the handle on from the top or bottom

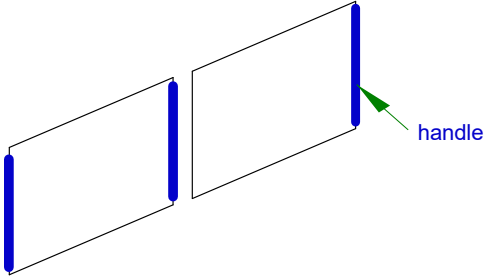
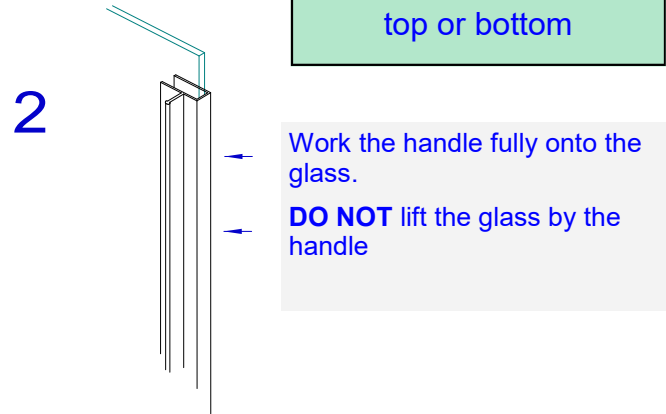

**HANDLES**  
 The right hand glass sheets always have 1 handle.  
 The left hand glass sheets always have 2 handles.

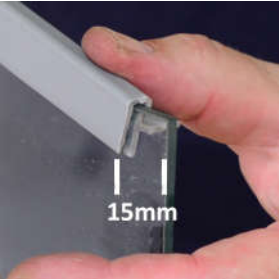

Work on handle from side edge



Handle fitted with 15mm gap



Sheet with 2 handles

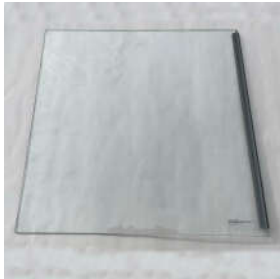

Sheet with 1 handle

### FITTING HANDLES

Fit the handles to the glass before fitting into the frame. Right hand panels always have a single handle on the right hand side of the sheet. Left hand panels have two handles, one on each side.

### FITTING THE FRONT & SIDE GLASS

To fit the glass push the sheet into the deeper top channel, then lower into the bottom channel (A). Make sure the glass is firmly in the bottom channel before letting go. When putting the sheets in the front of the frame, put the first sheet in at the right hand end. The second sheet will fit in front of the first sheet and overlap the first panel (B) by approx. 1" (2cm).

### FITTING THE ROOF GLASS

Fit the roof glass in the same way as the front glass, sliding the sheet into the deeper channel at the back. Once fitted, the two sheets should overlap in the centre (C).

### BACK GLASS

Slacken the four infill plate bolts and gently slide the first sheet in from the rear corner. Gently slide the other sheet in from the other end. The two sheets will overlap in the centre, behind the glass bracket (D). Carefully retighten the bolts. Fit a ring wedge (F) into the bottom glass channel - 1 per sheet.



A. Fitting the glass



B. Glass in channel with two sheets overlapping

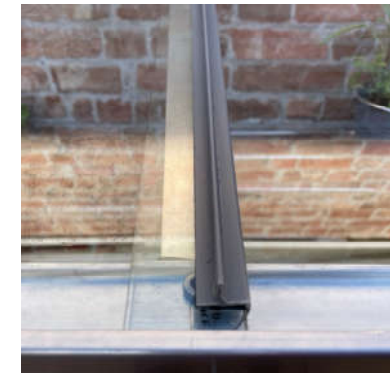

C. Roof glass overlapping

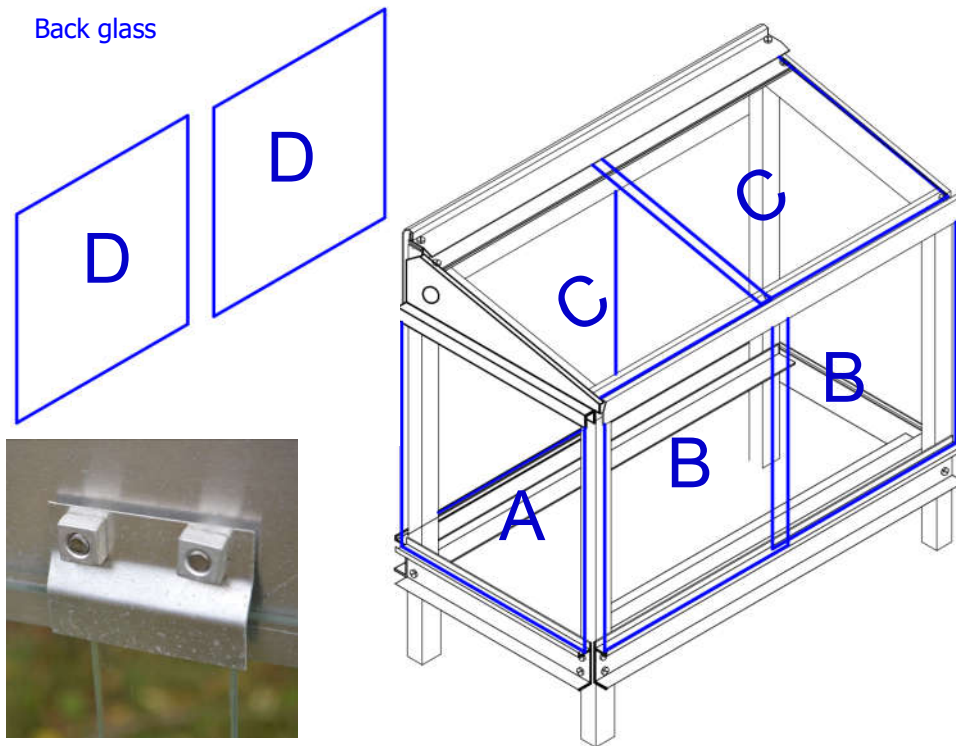

D. Glass bracket

GLASS		
A	500mm x 500mm	Qty: 2
B	500mm x 400mm	Qty: 2
C	500mm x 400mm	Qty: 2
D	500mm x 400mm	Qty: 2
End and rear glass have no handles		



F. Ring wedge

## FITTING THE GLASS

## BLACK 'WEDGES'

The small black thimble wedges (w) are designed to be pushed into the top channels of the end glass to stop the glass moving. Use two wedges per sheet of glass



Located in: SCREW-TH1

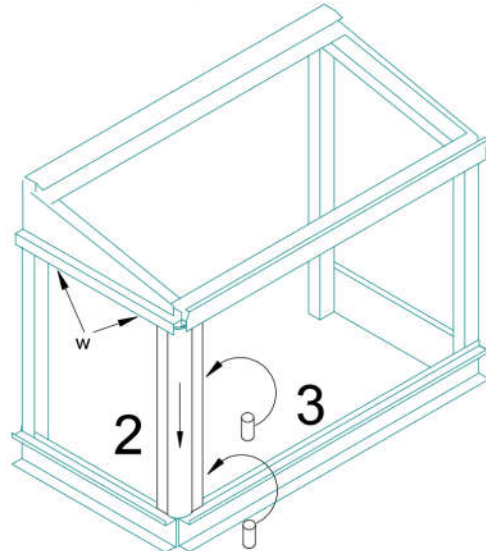
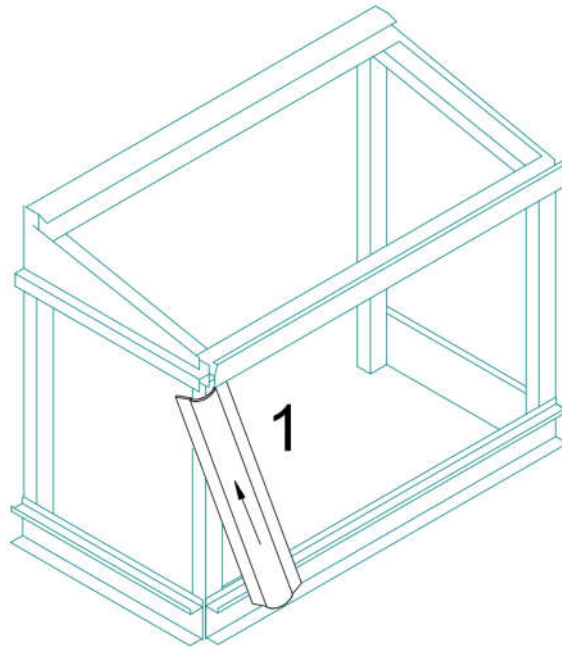

**NB—NO CORNER ANGLES  
REQUIRED FOR BACK OF FRAME**

## SLIDING THE FRONT GLASS

When closed, both panels will tuck behind the corner trims to keep them secure. Before sliding the right hand panel open, slide the left hand panel open by approx. 1" to release it from behind the corner trim.

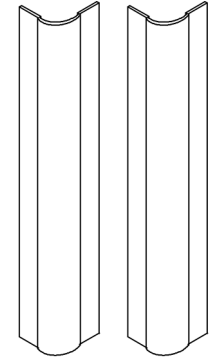

You also need:  
Bag marked as TRIM-4

## PARTS NEEDED



- 1 Take one of the corner trims and push it up into the top channel and the 'h' section.
- 2 Swing the corner trim in so that it is vertical and drop it into the channel below. At this point the trim will be loose.
- 3 Slide the front glass door out of the way. Take one of the hollow tubes contained in the pack marked 'TRIM'. From the front of the frame, push the tube between the framework and the corner trim. Slide the tube downwards as far as it will go.  
  
Insert a second hollow tube and repeat the action, but this time push the tube up as far as it will go.
- 4 Repeat for the other corner



Corner trim in place



Fitting the hollow tube



<p><b>GLASS STICKS TOGETHER</b></p>	<p>This is normally due to the handles not being put on the right side of the glass. See page 13 for details of where the handles should be fitted to the glass.</p> <p>If the glass has stuck together, push the two sheets to the back of the channel, then slowly pull the front sheet of glass forward from one end. This will release the suction between the sheets.</p>
<p><b>HANDLES COME OFF</b></p>	<p>As the handles are of a clamp design they can be pulled off if too much force is applied to them. If the glass has stuck together due to moisture, or if the glass does not slide smoothly, this will strain the clip part of the handle and cause it to come off.</p> <p>Ensure that the channels and the glass are kept clean at all times to minimise the sliding force needed. Candle wax applied to the channel and the underside of the glass will also help the sliding action. Also check that the handles have been fitted correctly. See page 12 for full instructions.</p> <p>Handles can be rejuvenated by placing them in hot water, cleaning them carefully, then squeezing the clip together while the plastic is still warm. Leave to cool before fitting.</p> <p>If handles come off frequently either purchase some new handles from Access or use a glue such as 'liquid nails' or 'no more nails' to permanently glue the handles to the glass.</p>
<p><b>SHELVES WILL NOT FIT INTO THE BACK LEGS</b></p>	<p>Check that the back legs have been fitted the right way round - see page 2.</p>
<p><b>WATERING INLET LEAKS</b></p>	<p>Try tightening the inlet fitting as it needs to be tight to seal.</p>

## **PERIODIC MAINTENANCE**

Every Spring take the glass out of the greenhouse and wash glass and framework with warm soapy water.

When inserting the glass, always check that the glass is properly seated in its top and bottom channels before letting go of the sheet.

**CHECK THE TIGHTNESS** of all bolts regularly, especially in very windy areas or powder coated frames.

**CROP ROTATION** Suggestions for suitable crops and sowing dates given in the free Access Growing Guide

**VENTILATION** In cold weather gentle ventilation can be given by sliding the four front sheets of glass to give 2-3" (5-8cm) gap at each corner.

In warmer weather allow a gap on the top sheets as well. In very hot weather open all the sheets of glass.

To ensure that the correct temperature is maintained use a thermometer inside the greenhouse. You can completely remove the top sheets in summer. Access shading will help keep temperatures down, and stop birds etc getting inside. The Access Automatic Vent will look after ventilation - automatically!

**GALES** The greenhouse must be kept fully closed in rough weather.

**GLASS CHANNELS** Ensure that this is kept free from debris and allows the glass to slide smoothly. Periodically lubricate the running edge of the glass with a wax candle.

**SNOW** If snow is very heavy - avoid letting it build up on the roof

**SHELVING** Stand pot plants on saucers, or use optional shelf covers which incorporate a layer of capillary matting to absorb excess water when watering. Alternatively, stand the pots in empty seed trays.

**WATERING SYSTEM** The system accepts standard quick connectors. Turn the tap on slowly until the mist fills the greenhouse; too much pressure will throw water on to the back wall. Leave on for 5 minutes, or ½ minute for damping down.

**SITING** Site on the sunniest place available. Anything from East through South to West is suitable. If it has to face North, don't despair, it will be warmer in than outside! If you can fix to a brick or stone wall, you will get extra heat storage during the day.