

# ASSEMBLY INSTRUCTIONS

## Eltham-D

### CONTENTS

Main aluminium parts	P1
End sections	P2
Adding the long rails	P3
End plates	P4
Centre legs	P5
Squaring & fixing	P6
Back rails	P7
Back corner trims	P8
Shelving	P9
Watering	P10
Fitting liner	P11
Fitting handles	P12
Fitting glass	P13
Front corner trims	P14
Troubleshooting	P15
Notes on using the frame	P16

#### Video instructions:

Helpful video clips are available at

[www.garden-products.co.uk/instructions](http://www.garden-products.co.uk/instructions)



#### Can we improve?

We hope that you find our instructions clear and concise. If you have any suggestions for improvements email:

[instructionfeedback@garden-products.co.uk](mailto:instructionfeedback@garden-products.co.uk)

Please keep all packaging until installation is complete

Access Garden Products  
Crick  
NORTHAMPTON  
NN6 7XS

Tel: 01788 822301  
Fax: 01788 824256  
[sales@garden-products.co.uk](mailto:sales@garden-products.co.uk)  
[www.garden-products.co.uk](http://www.garden-products.co.uk)

Assembly instructions for model: Eltham-D AX2(1.00m/3'4") BX2(1.51m/5'0") CX2(1.94m/6'5")

Date: June 2023 Rev 12 File: X2

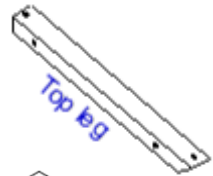

Top leg



Back Leg



Front Leg

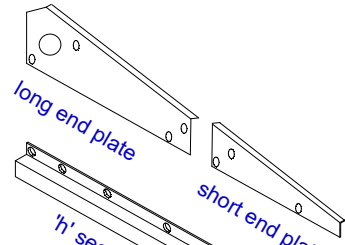

long end plate

short end plate

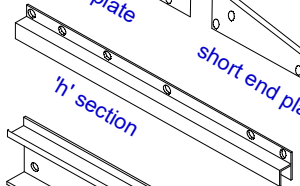

'h' section

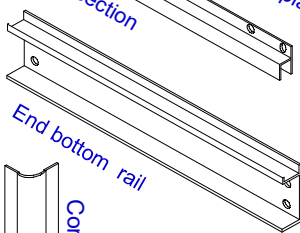

End bottom rail

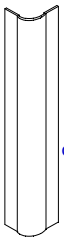

Corner angle

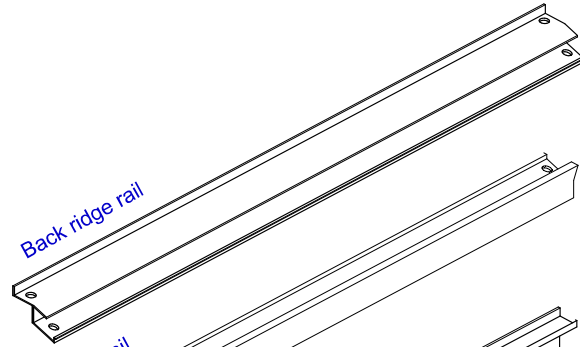

Back ridge rail

Front top rail

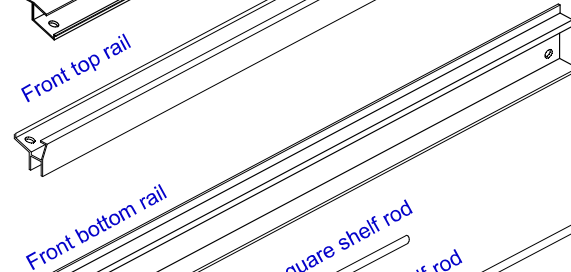

Front bottom rail

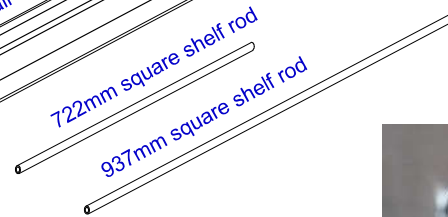

722mm square shelf rod

937mm square shelf rod

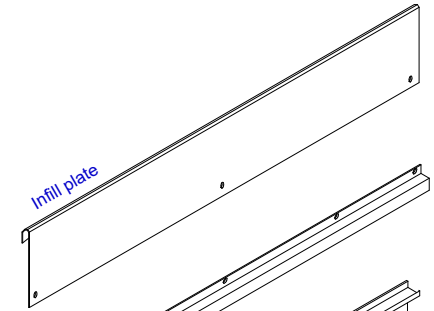

Infill plate

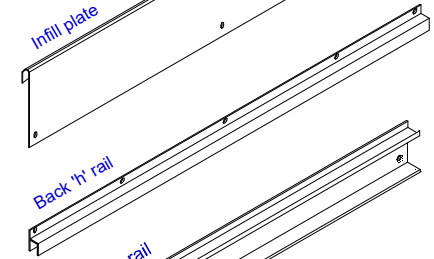

Back 'h' rail

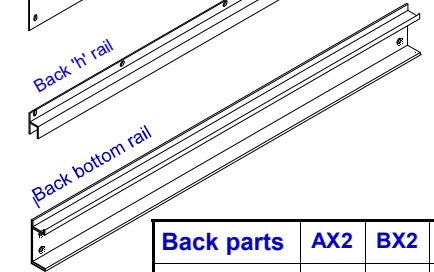

Back bottom rail

Back parts	AX2	BX2	CX2
Infill plate	1	2	2
'h' rail	1	1	1
Bottom rail	1	1	1



**FIT THE WASHER UNDER THE HEAD OF ALL HEX HEAD BOLTS UNLESS OTHERWISE INSTRUCTED.**

Leg parts	AX2	BX2	CX2
Back leg	2	3	3
Front leg	2	3	3
Top leg	2	3	3

End parts	AX2	BX2	CX2
End plate	2+2	2+2	2+2
'h' section	2	2	2
Bottom rail	2	2	2
Corner Angle	4	4	4

Front parts	AX2	BX2	CX2
Ridge rail	1	1	1
Top rail	1	1	1
Bottom rail	1	1	1
722mm shelf rod	0	16	0
937mm shelf rod	8	0	16

Additional Items		AX2	BX2	CX2
Handle 725mm		9	9	9
Grey watering pipes		2	3	3
Watering pack	I-SP-1	1	1	1
Screw packs	SCREW-H1	1	1	1
	SCREW-H6	1	1	1
Anchorage pack	FR-AK	2	2	2
Wide shelf pack	S-W2	1	2	2
Trim pack	TRIM-4	2	2	2
Black channel liner	W65-5M	1	2	2
White channel liner	W66-2M	1	1	1
Allen key	SCREW-H1			



Top leg rests against the **FLAT FACE** of back leg—it is not bolted to the back leg



Slide the tongue of the front leg into the groove on the top leg.

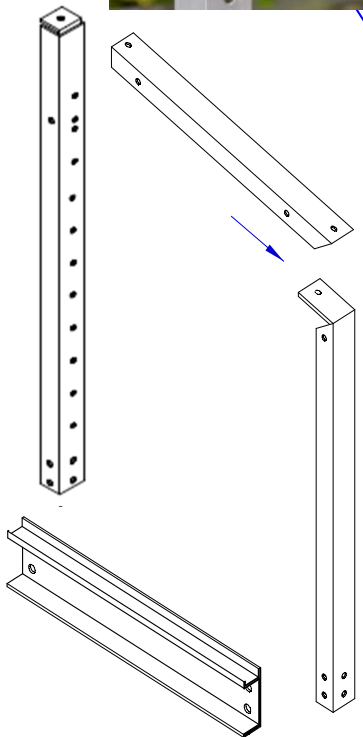

EXPLODED VIEW

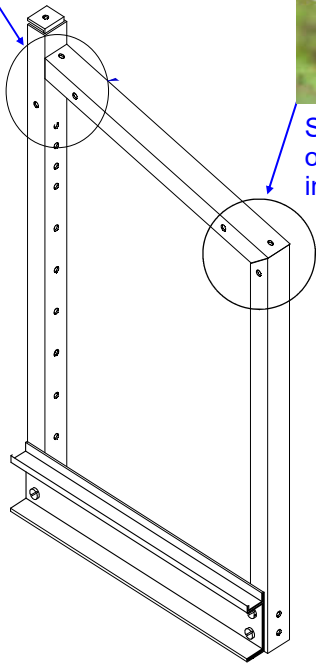

FINISHED LEFT HAND END

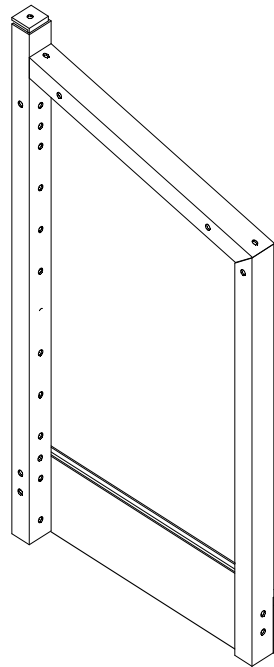

FINISHED RIGHT HAND END

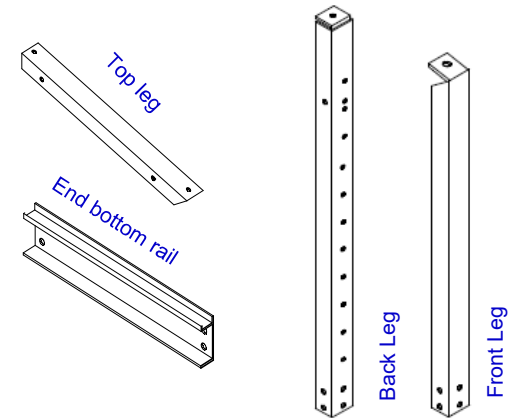

**YOU ALSO NEED:**

10mm BOLTS	4
METAL WASHERS	4
NUTS	4
Located in pack: SCREW-H1	

**PARTS NEEDED FOR EACH END**

- 1 Make up the LEFT hand end as shown.
- 2 Make up the RIGHT hand end as shown

**DO NOT FULLY TIGHTEN BOLTS AT THIS STAGE**



FIXING DETAIL

**DO NOT FIT A WASHER AT POINTS MARKED X**  
 ON POWDERCOATED UNITS  
 TAKE CARE NOT TO  
 OVERTIGHTEN THESE BOLTS  
 OTHERWISE THE COATING WILL  
 BE DAMAGED

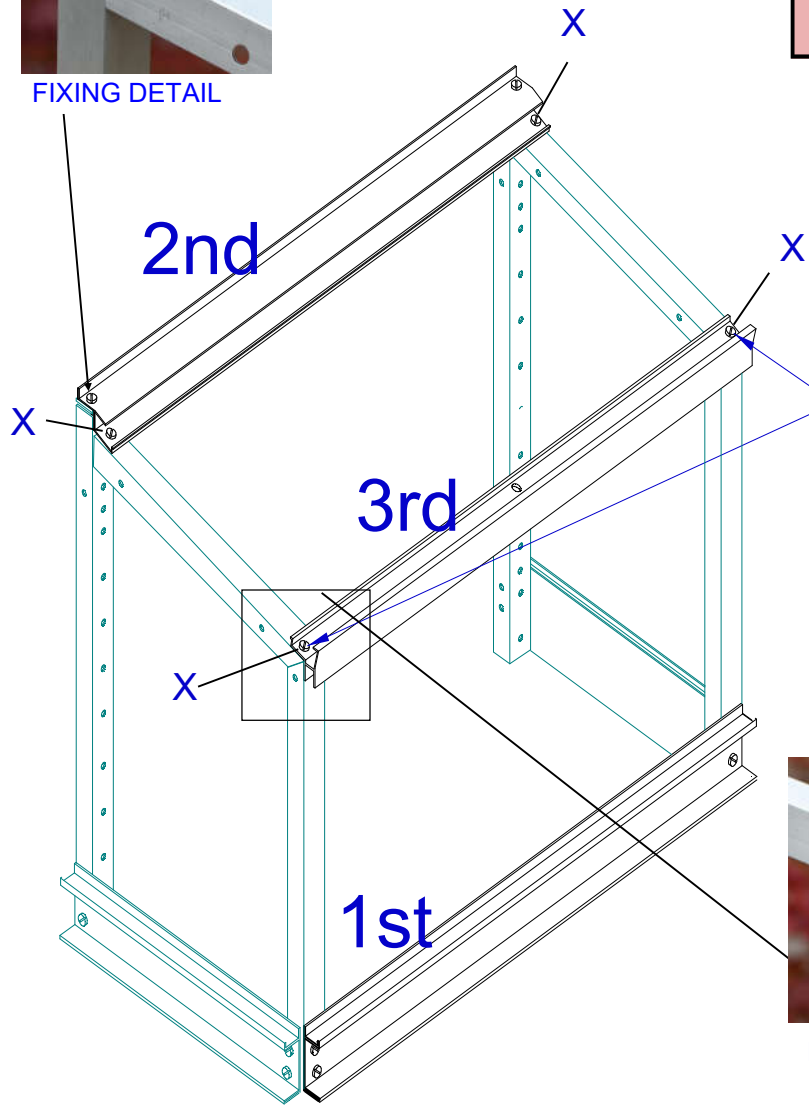

USE THE TWO 20MM  
 BOLTS WITH THIS RAIL



FIXING DETAIL

**PARTS NEEDED**



**YOU ALSO NEED:**

10mm BOLTS	8
20mm BOLTS	2
METAL WASHERS	6
NUTS	10
Located in pack: SCREW-H1	

**1** Bolt on the rails in the order shown.

**DO NOT FULLY TIGHTEN BOLTS AT THIS STAGE**

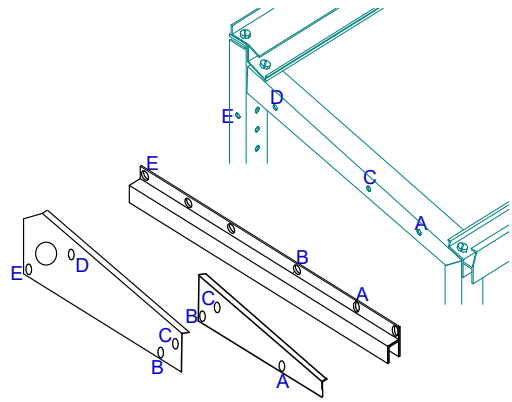

EXPLODED VIEW  
LEFT HAND END

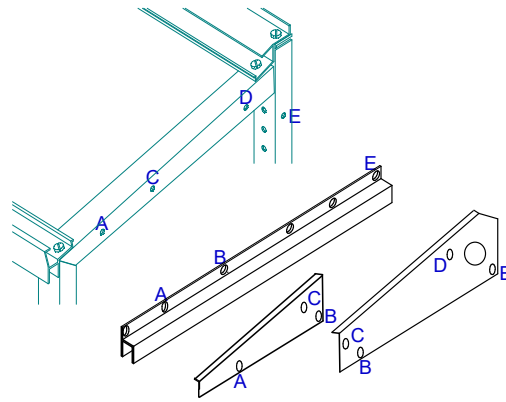

EXPLODED VIEW  
RIGHT HAND END

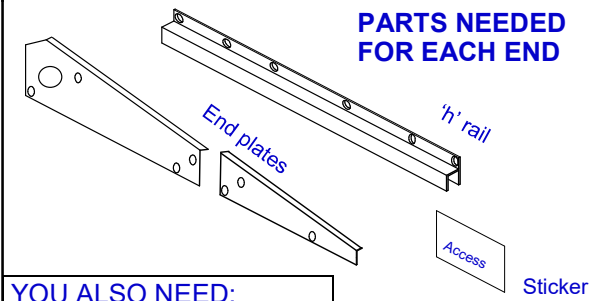

**YOU ALSO NEED:**

10mm BOLTS	5
METAL WASHERS	5
NUTS	5
Located in pack: SCREW-H1	



THE END PLATE  
FITS UNDER THE  
RIDGE RAIL LIP

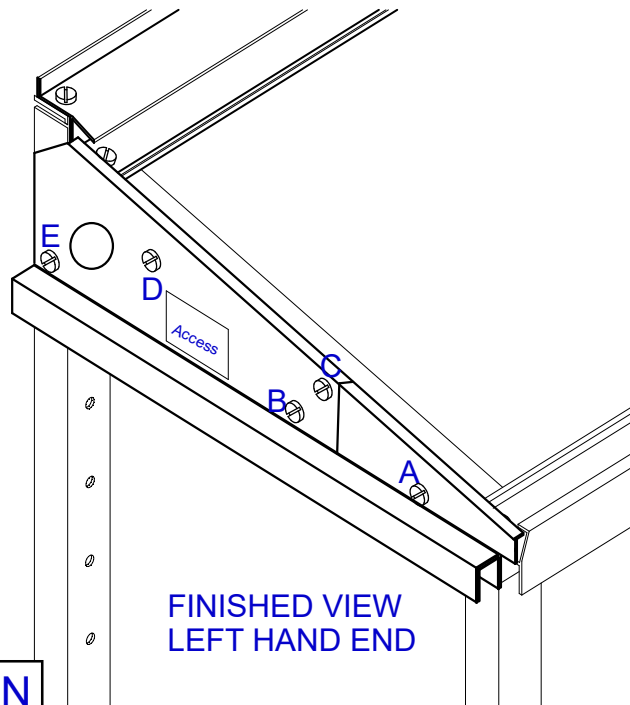

FINISHED VIEW  
LEFT HAND END



THE END PLATE  
FITS UNDER THE  
FRONT RAIL LIP

IF YOU HAVE AN  
AX2 MODEL  
GO TO PAGE 6

- 1 **Remove any plastic protective film** from the end plates and put 'Access' sticker on the large end plates.
- 2 To make the left hand end: Bolt the two end plates and the 'h' section together using bolt 'B'. The long end plates fits on the outside of the short end plate.
- 3 Bolt the assembly onto the frame using bolts 'A' and 'E'. Fit bolts 'C' and 'D'.
- 4 Repeat for the other end.

**DO NOT FULLY TIGHTEN  
BOLTS AT THIS STAGE**

DO NOT FIT A WASHER AT THE 2 POINTS MARKED X IF POWDERCOATED TAKE CARE NOT TO OVERTIGHTEN BOLT AS WILL DAMAGE PAINT

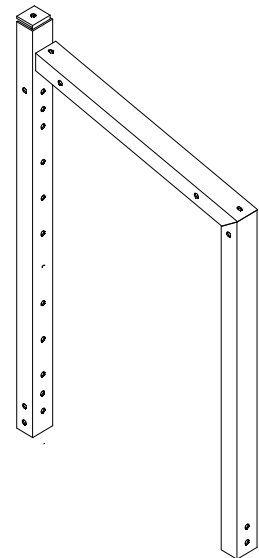
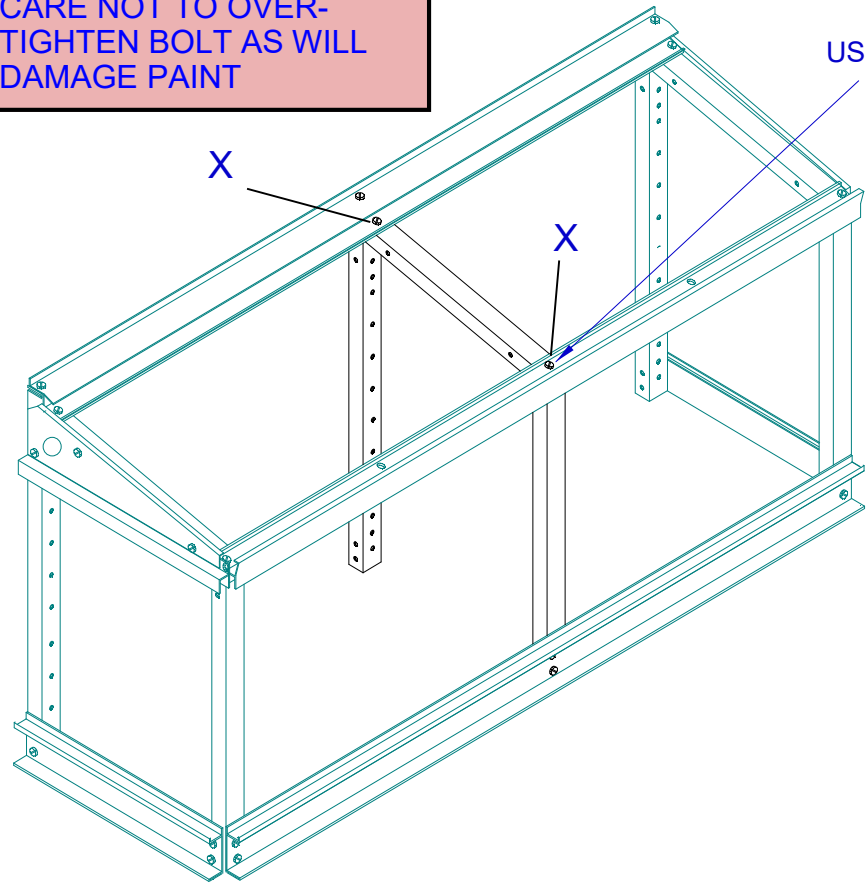

CENTRE LEGS PRIOR TO FITTING

PARTS NEEDED

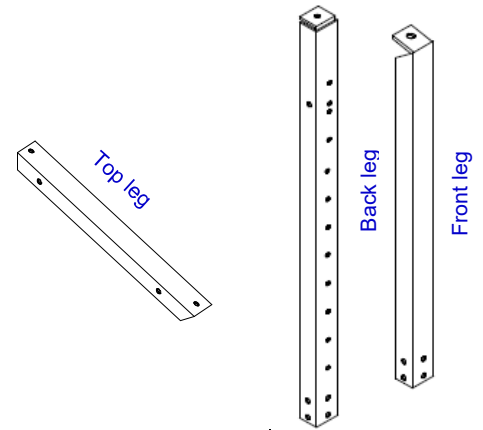

YOU ALSO NEED:

10mm BOLTS	4
20mm BOLTS	1
METAL WASHERS	4
NUTS	5
Located in pack: SCREW-H1	

1 Fit legs as shown into the frame.

DO NOT FULLY TIGHTEN BOLTS AT THIS STAGE

# 1

## SQUARING THE FRAME

Use a piece of glass to square the unit up as shown. Slacken the nuts if necessary to move the framework into a square position.

Once the frame is completely square tighten up all the nuts.

Remove glass once squaring is complete.

**FULLY TIGHTEN ALL BOLTS**

## PARTS NEEDED

Anchorage pack FR-AK x 2

# 2

## FIXING TO FLOOR

Fit the 'L' brackets to the front legs using a nut and bolt.

Turn the framework upside down and fit the 'L' brackets to the back legs using a nut and bolt.

Place the framework in its final position and drill through the bracket with a 6mm masonry drill bit, to a depth of 35mm. Insert the red rawlplug, through the bracket and into the concrete.

Using a woodscrew, screw through the 'L' bracket and into the rawlplug.

Repeat for other brackets.

**WEAR APPROPRIATE SAFETY EQUIPMENT WHEN DRILLING OR HAMMERING**

If this nut turns while tightening, use a small pair of pliers to hold the nut

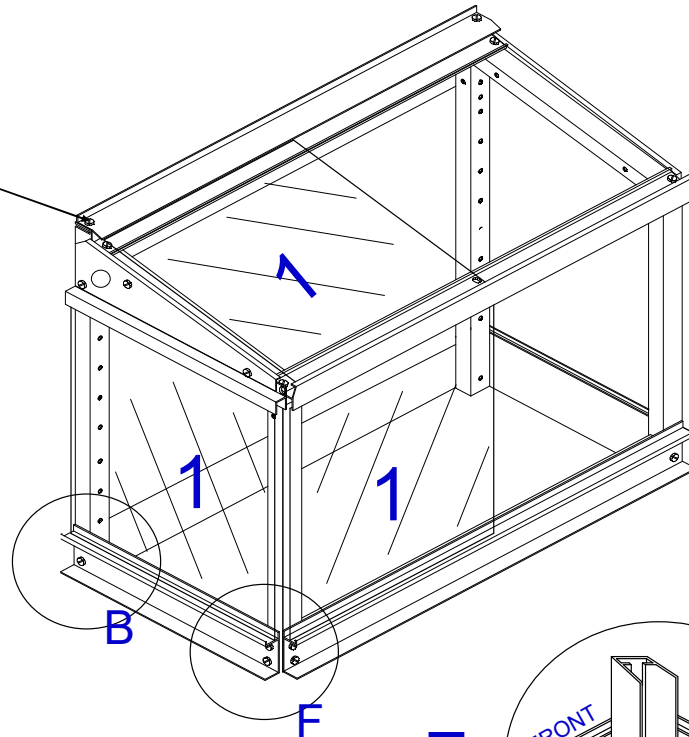

# B

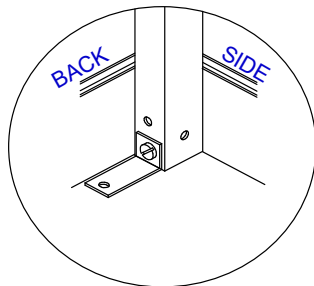

INSIDE VIEW OF BACK LEG SHOWING FIXING

# F

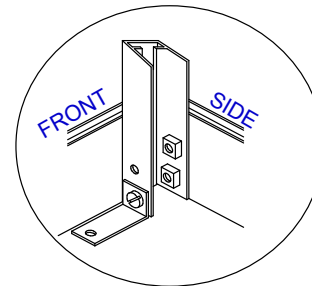

INSIDE VIEW OF FRONT LEG SHOWING FIXING



Completed front bracket

2a

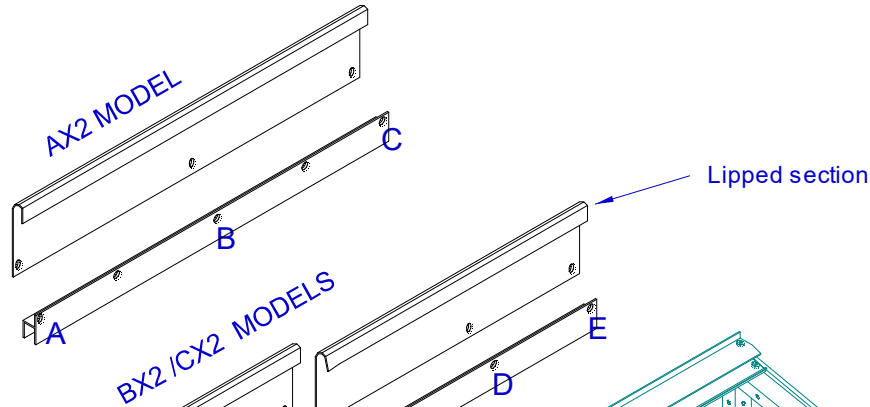

2b

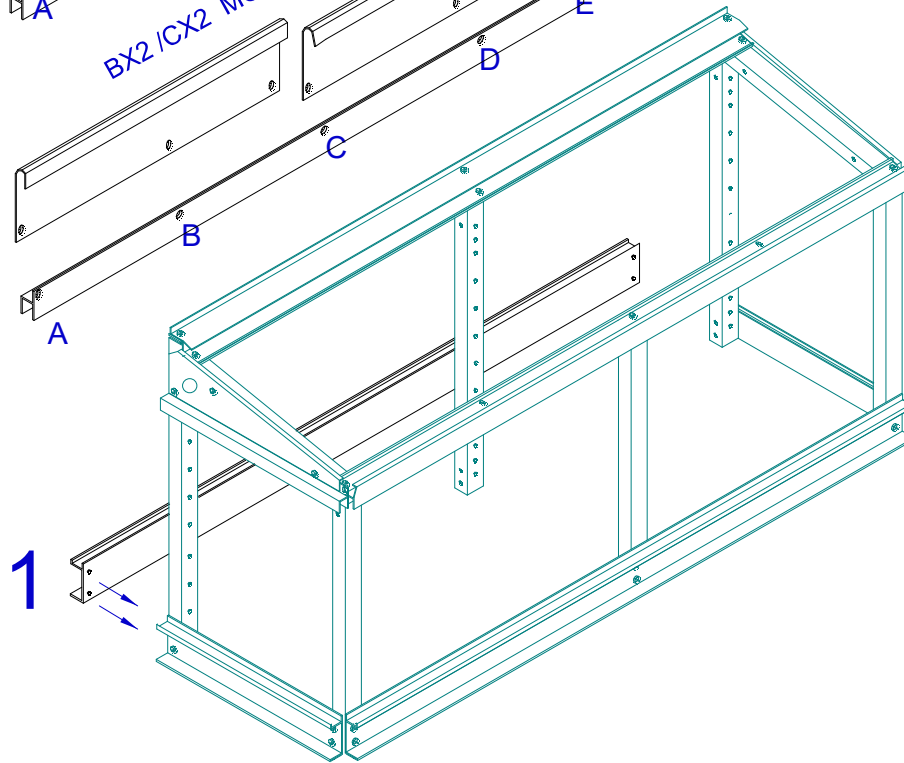

1

1

Bolt on back bottom rail. Put a metal washer on the 40mm bolt and push through bottom rail then fit a 20mm nylon spacer BEFORE passing through the leg and fitting a nut on the inside of the frame. Repeat for the other holes in the rail.

**FULLY TIGHTEN ALL BOLTS**

## PARTS NEEDED

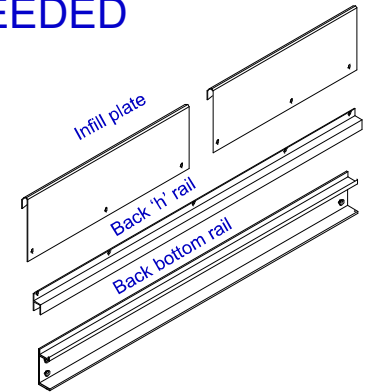

PARTS ALSO NEEDED	AX2	BX2
10mm BOLTS	1	2
40mm BOLTS	6	9
METAL WASHERS	7	11
NUTS	7	11
20mm NYLON SPACERS	6	9
Located in pack:	SCREW-H6	

**Remove the plastic protective film from the infill plate(s)**

**FIT THE WASHER UNDER THE HEAD OF ALL HEX HEAD BOLTS**

2a

**AX2 model**

Bolt infill plate to 'h' rail through hole 'B', using 10mm bolt.

2b

**BX2/CX2 models**

Bolt the NOTCHED infill plate to 'h' rail, using a 10mm bolt through hole 'B'. Using the second infill plate, overlap the first plate and bolt through 'D' with a 10mm bolt.

3

Place the lipped section over the upstand on the back rail. Push a 40mm bolt through hole A, then fit a nylon spacer. Push the bolt into the frame and fit a nut. Repeat at other end (hole C on AX2 models or holes C & E on BX2/CX2 models)



## PARTS NEEDED

Aluminium corner trims

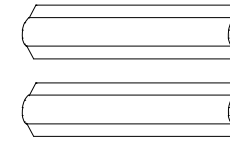

You also need: 2 bags  
marked as TRIM-4



- 1 Take one of the corner trims and push it up into the back 'h' rail and the 'h' section.  
Swing the corner trim so that it is vertical and drops into the channel below.

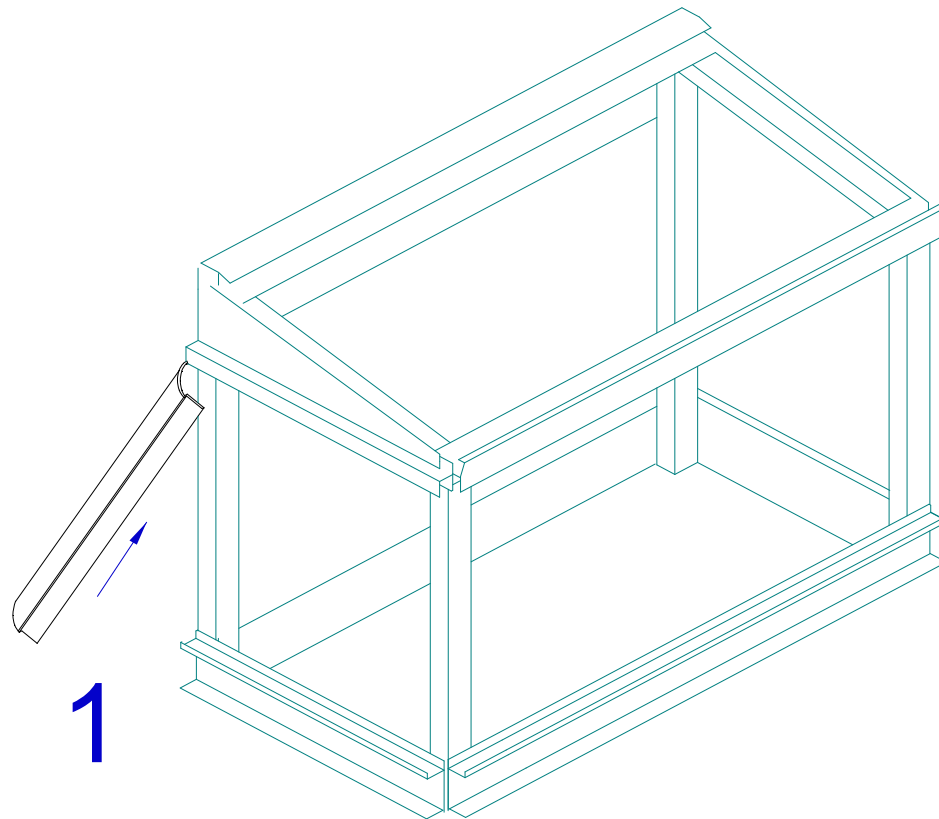

Fitting the hollow tube

2

Plan View

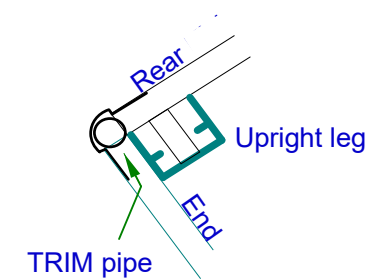

2

Working from the end of the frame, push the TRIM tube between the corner trim and the framework. Slide the tube down as far as it will go.

Fit a second TRIM tube and slide up as far as it will go.

Repeat for the other end.

The AX2 model has 2 wide full length shelves.

The BX2 & CX2 models have 4 wide half length shelves.

- 1 Lightly tap rawplug inserts into both ends of the tubular aluminium shelf rods with a hammer.
- 2 Screw the support brackets on to each end EXCEPT for the rod that has the support wires.
- 3 For the rod with the support wires put the spacer and the support wire onto the screw BEFORE passing through the bracket.

## FITTING

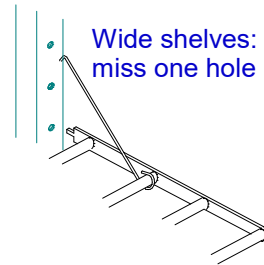

Hook support wire into top hole, then swing shelf upward into the hole. Make sure flat face of shelf rod is uppermost.

## PARTS NEEDED

Square rod profile  
Flat face is uppermost

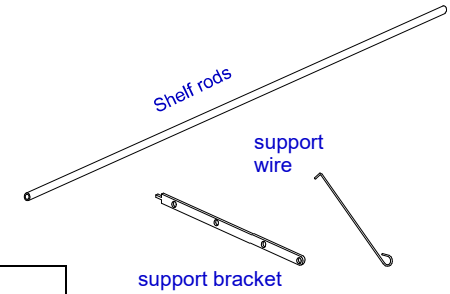

### YOU ALSO NEED PER SHELF ROD:

RAWLPLUG	2
WOOD SCREW	2
Located in packs: S-W2	

### YOU ALSO NEED PER COMPLETE SHELF:

NYLON SPACER	2
Located in packs: S-W2	

### NEW 5-hole strap

Fit the rods to the holes 'F' - the rod with support wire is marked SW. The centre hole is unused.

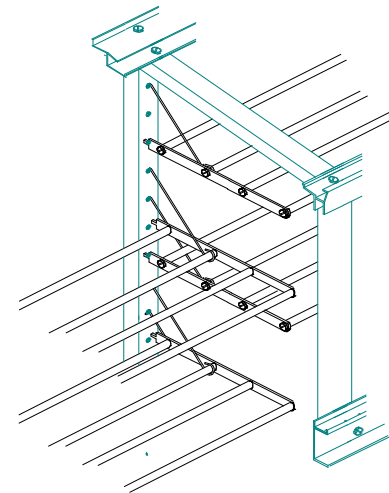
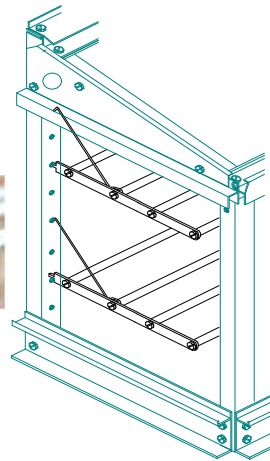
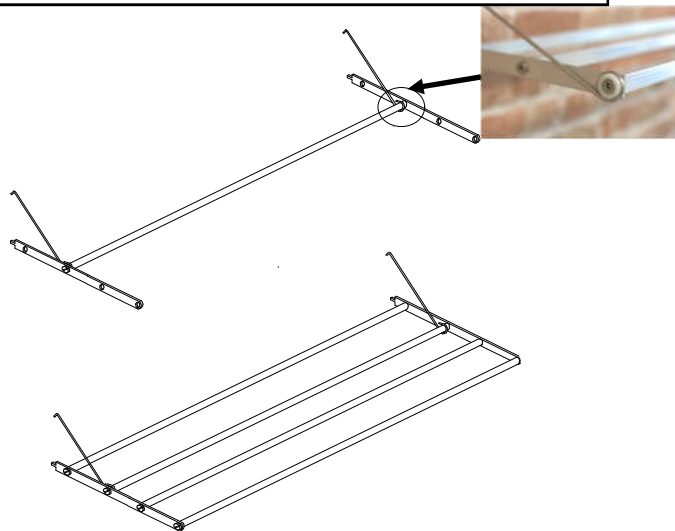
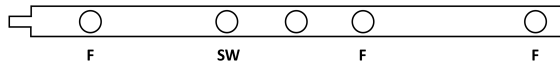

The large number of holes in the back leg allow the spacing of the shelves to be easily altered.

When the shelves are not needed they can either be removed or they can be unhooked from the lower fixing hole and hung flat against the back using the wires.

## HALF LENGTH SHELF FITTING

Support wires can share same hole as support bracket



Bottom shelf hung flat against the back

Note: A Pozidrive screwdriver will fit the screws best

1

Choose which end you would like the watering inlet.



Fit the washer onto the thread of the adaptor, and then fit the

Push the assembly through the hole from the inside

Screw the brass elbow onto the protruding thread from the outside

**TIP:** Dip the end of the grey pipe in water. For a better fit, twist the pipes as they are inserted.

2

'L' shape brackets need to be fitted inside the frame.  
x - Use a nut and bolt to fix to the hole

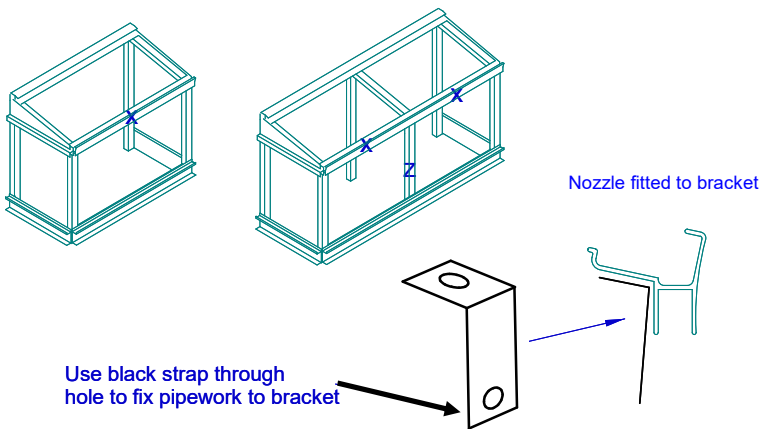

Use black strap through hole to fix pipework to bracket

4

Use the black straps to secure the watering system to the 'L' shaped brackets and then strap the pipes to the end of the frame using the hole in the leg. The long strap is used to secure the pipe to the top leg at position 'Z' (BX2 & CX2 only).

Fit the black grommet (from pack SCREW-H1) into the unused irrigation hole at the opposite end of the unit.

3

Fit the irrigation system as shown. The grey tubes push into the black fittings. Ensure the open face of the grey nozzle faces into the frame.

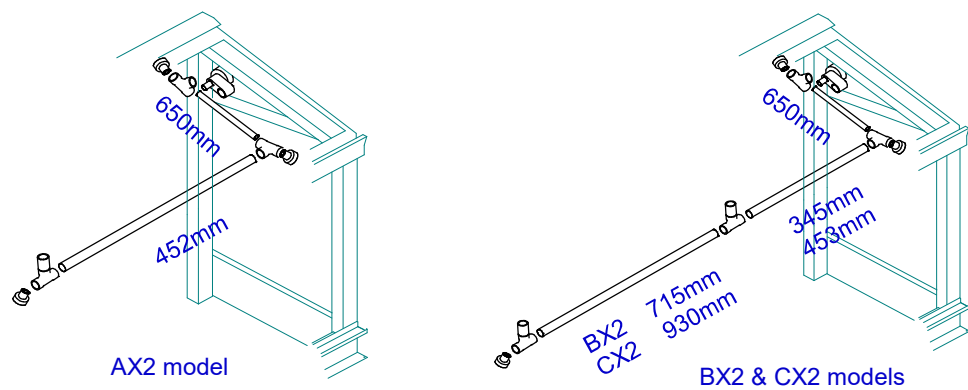

PARTS NEEDED:		
NOZZLE ASSEMBLY	AX2 B/CX2	1 2
SINGLE TEE		2
BLANKING PLUG		3
'L' BRACKET	AX2 B/CX2	1 2
GREY PIPES	AX2 B/CX2	2 3
ENTRY FITTING: Nipple, adaptor, washer and brass elbow		1
10MM BOLTS & NUTS	AX2 B/CX2	1 2
BLACK STRAPS (short)		3
BLACK STRAPS (long)		1
Located in pack: I-SP-1		



Blanking grommet



Inlet and link pipe



Nozzle strapped to 'L' bracket

# FITTING THE CHANNEL LINER

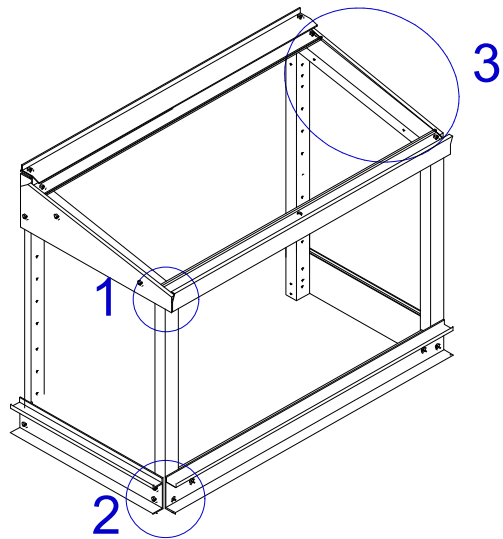

Before sticking the tape, clean the aluminium of any oil traces to promote adhesion.

**1** The white liner (W66-2M) fits on the inside vertical face of top FRONT rail only. This is a loose fit so strips of double sided tape are included to secure it until the glass is in place.

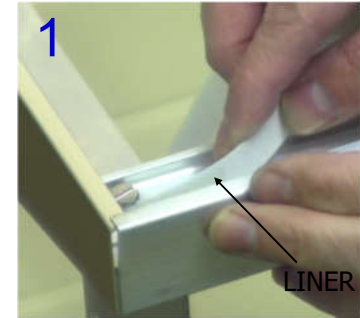
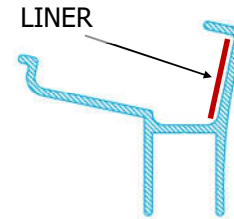

**2** The black plastic liner (W65-5M) goes in the FRONT and REAR bottom rails only. Using the strips of double sided tape press liner down so that it LIES FLAT at the bottom of the channel - trim with a knife if necessary.

THE DOORS WILL NOT SLIDE PROPERLY IF THE LINER IS NOT FLAT

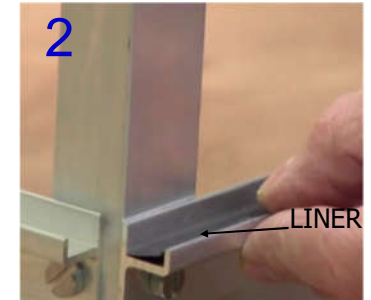

**3** To make the top glass slide more easily, rub candle wax onto the glass bearers. Also wax the black and white liners.

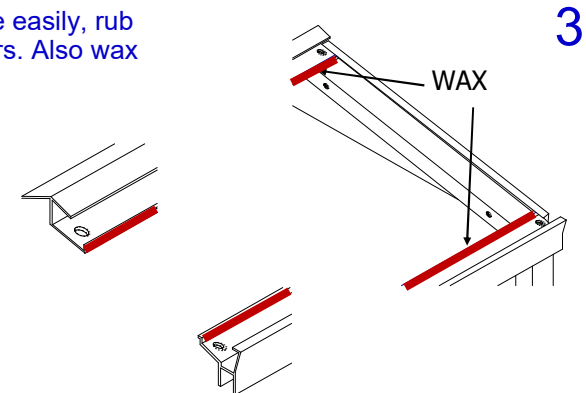

# FITTING THE HANDLES

When fitting the handles, place the glass on a table or timber battens.  
**NEVER PLACE THE GLASS DIRECTLY ON CONCRETE OR SLABS**

**WARNING**  
 If broken, toughened glass will fragment safely.  
 If the edges are knocked or chipped the glass will spontaneously fragment. This is a natural occurrence due to the toughening process. Care should be taken when moving or cleaning, not to damage the edge of the glass.  
 When placing the glass in the frame, ensure that the glass is securely placed in the runners before letting go of the glass.

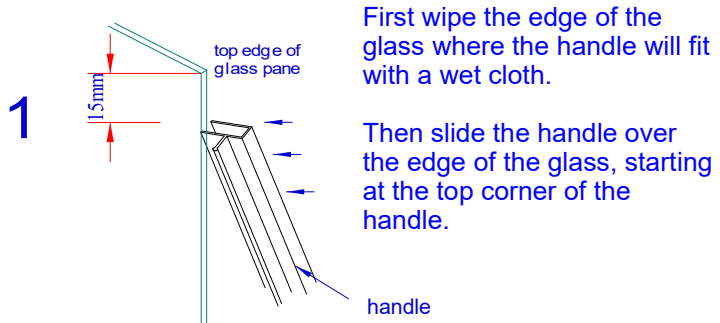

First wipe the edge of the glass where the handle will fit with a wet cloth.

Then slide the handle over the edge of the glass, starting at the top corner of the handle.

**TIP:** Always grip the handle in the **CENTRE** when sliding

SEE PAGE 12 FOR WHICH GLASS SHEETS NEED HANDLES	'B' sheet	'C' sheet
Sheets requiring one handle	1	2
Sheets requiring two handles	1	2

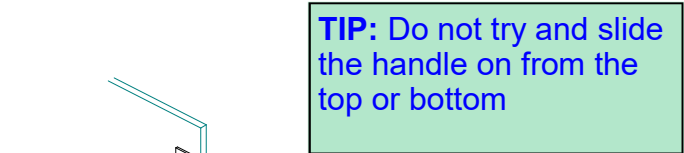

Work the handle fully onto the glass.  
**DO NOT** lift the glass by the handle

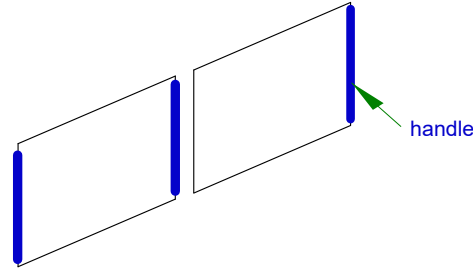

## HANDLES

The right hand glass sheets always have 1 handle.  
 The left hand glass sheets always have 2 handles.

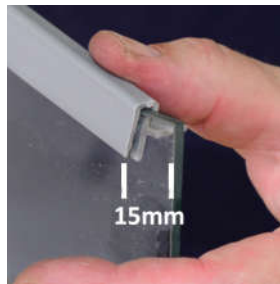

Work on handle from side edge



Handle fitted with 15mm gap



Sheet with 2 handles



Sheet with 1 handle

### FITTING HANDLES

Fit the handles to the glass before fitting into the frame. Right hand panels always have a single handle on the right hand side of the sheet. Left hand panels have two handles, one on each side.

### FITTING THE GLASS

To fit the glass push the sheet into the deeper top channel, then lower into the bottom channel (A). Make sure the glass is firmly in the bottom channel before letting go. When putting the sheets in the frame, put the first sheet in at the right hand end. The second sheet will fit in front of the first sheet and overlap the first panel by approx. 1" (2cm).

### SLIDING THE FRONT AND REAR GLASS

When closed, both panels will tuck behind the corner trims to keep them secure. Before sliding the right hand panel open, slide the left hand panel open by approx 1" to release it from behind the corner trim.



A. Fitting the glass

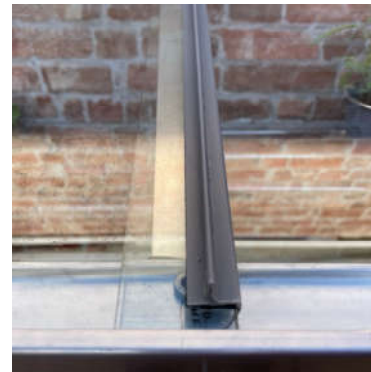
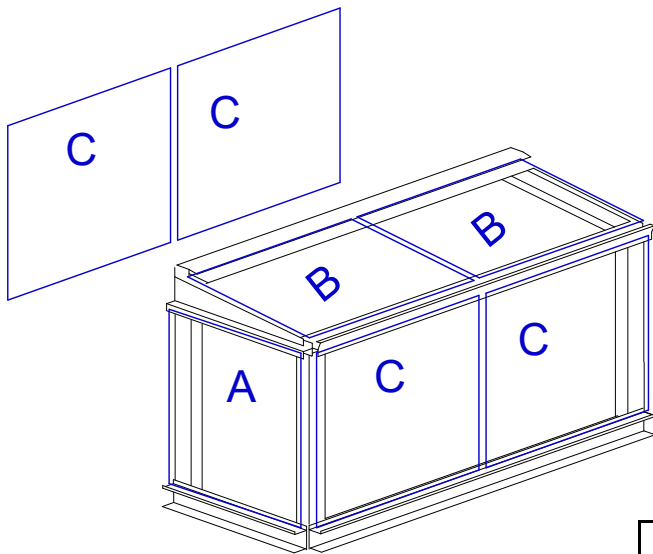

Roof glass overlapping

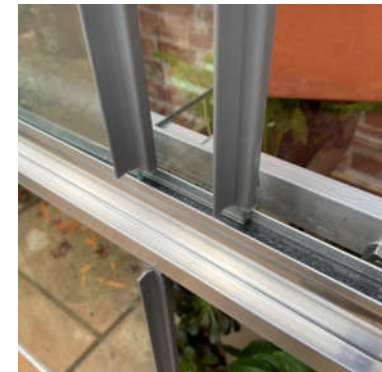

Glass in channel with two sheets overlapping

AX2 3'4" Eltham-D			BX2 5'0" Eltham-D			CX2 6'5" Eltham-D		
A	750mm x 750mm	Qty: 2	A	750mm x 750mm	Qty: 2	A	750mm x 750mm	Qty: 2
B	750mm x 500mm	Qty: 2	B	750mm x 750mm	Qty: 2	B	965mm x 750mm	Qty: 2
C	750mm x 500mm	Qty: 4	C	750mm x 750mm	Qty: 4	C	965mm x 750mm	Qty: 4
End glass (A ) has no handles								

## BLACK 'WEDGES'

The small black thimble wedges (w) are designed to be pushed into the top channels of the end glass to stop the glass moving. Use two wedges per sheet of glass.



Located in pack: SCREW-H1

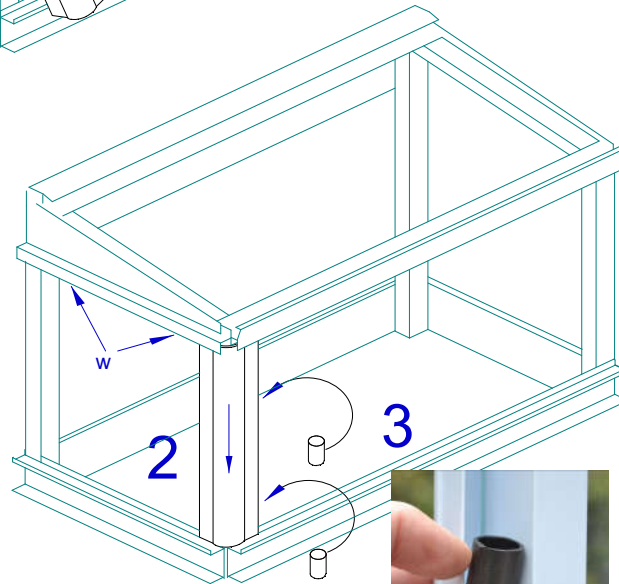
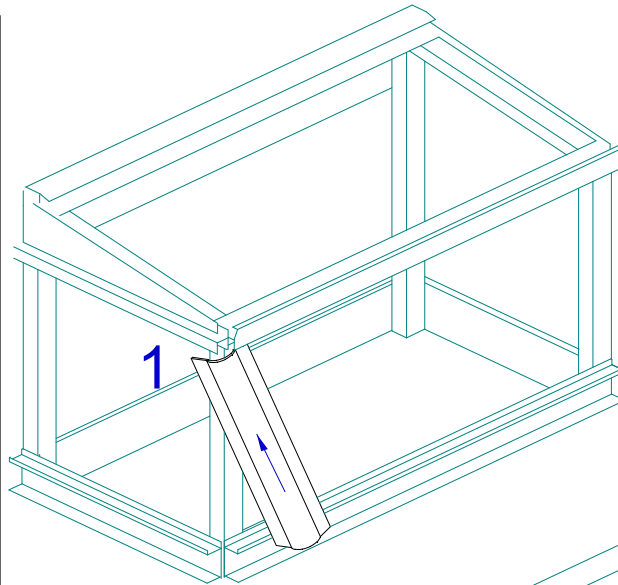

Corner trim in place



Fitting the hollow tube

## Aluminium corner trims

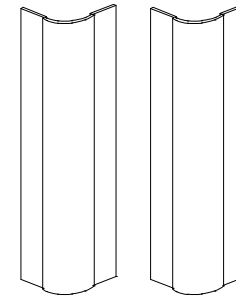

You also need: 2 bags marked as TRIM-4

## PARTS NEEDED



- 1 Take one of the corner trims and push it up into the top channel and the 'h' section.
- 2 Swing the corner trim in so that it is vertical and drop it into the channel below. At this point the trim will be loose.
- 3 Slide the front glass door out of the way. Take one of the hollow tubes contained in the pack marked 'TRIM'. From the front of the frame, push the tube between the framework and the corner trim. Slide the tube downwards as far as it will go.  
  
Insert a second hollow tube and repeat the action, but this time push the tube up as far as it will go.  
  
These tubes keep the corner trim firmly in place, and act as a stop for the sliding doors.
- 4 Repeat for the other corner.

<b>CORNER TRIMS WILL NOT FIT</b>	The most common cause of this problem is the end glass protruding over the front leg. This is normally caused because the frame work is not square against the wall. See page 7.
<b>GLASS STICKS TOGETHER</b>	<p>This is normally due to the handles not being put on the right side of the glass. See page 12 for details of where the handles should be fitted to the glass.</p> <p>If the glass has stuck together, push the two sheets to the back of the channel, then slowly pull the front sheet of glass forward from one end. This will release the suction between the sheets.</p>
<b>HANDLES COME OFF</b>	<p>As the handles are of a clamp design they can be pulled off if too much force is applied to them. If the glass has stuck together due to moisture, or if the glass does not slide smoothly, this will strain the clip part of the handle and cause it to come off.</p> <p>Ensure that the channels and the glass are kept clean at all times to minimise the sliding force needed. Candle wax applied to the channel and the underside of the glass will also help the sliding action. Also check that the handles have been fitted correctly. See page 12 for full instructions.</p> <p>Handles can be rejuvenated by placing them in hot water, cleaning them carefully, then squeezing the clip together while the plastic is still warm. Leave to cool before fitting.</p> <p>If handles come off frequently either purchase some new handles from Access or use a glue such as 'liquid nails' or 'no more nails' to permanently glue the handles to the glass.</p>
<b>SHELVES WILL NOT FIT INTO THE BACK LEGS</b>	<p>Check that the back legs have been fitted the right way round - see page 2.</p> <p>Check that dimension A = B - see page 7.</p>
<b>LOUVRE VENT DOES NOT FULLY CLOSE ON COLD DAYS</b>	<p>Loosen the two screws which hold the automatic opener to the vent. Push the opener up as far as it will go. Retighten the 2 screws.</p> <p>If the unit still does not fully close, lubricate the opener mechanism and all the pivot points with WD-40</p>
<b>WATERING INLET LEAKS</b>	<p>Try tightening the inlet fitting as it needs to be tight to seal.</p>



## **PERIODIC MAINTENANCE**

Every Spring take the glass out of the greenhouse and wash glass and framework with warm soapy water.

Lubricate the automatic louvre vent bi-monthly and remove if subject to very heavy frosts.

When inserting the glass, always check that the glass is properly seated in its top and bottom channels before letting go of the sheet.

**CHECK THE TIGHTNESS** of all bolts regularly, especially in very windy areas or powder coated frames.

**CROP ROTATION** Suggestions for suitable crops and sowing dates given in the free Access Growing Guide

**VENTILATION** In cold weather gentle ventilation can be given by sliding the four front sheets of glass to give 2-3" (5-8cm) gap at each corner.

In warmer weather allow a gap on the top sheets as well. In very hot weather open all the sheets of glass.

To ensure that the correct temperature is maintained use a thermometer inside the greenhouse. You can completely remove the top sheets in summer. Access shading will help keep temperatures down, and stop birds etc getting inside. The Access Automatic Vent will look after ventilation - automatically!

**GALES** The greenhouse must be kept fully closed in rough weather.

**GLASS CHANNELS** Ensure that this is kept free from debris and allows the glass to slide smoothly. Periodically lubricate the running edge of the glass with a wax candle.

**SNOW** If snow is very heavy - avoid letting it build up on the roof

**SHELVING** Stand pot plants on saucers, or use optional shelf covers which incorporate a layer of capillary matting to absorb excess water when watering. Alternatively, stand the pots in empty seed trays.

**WATERING SYSTEM** The system accepts standard quick connectors. Turn the tap on slowly until the mist fills the greenhouse; too much pressure will throw water on to the back wall. Leave on for 5 minutes, or ½ minute for damping down.

**SITING** Site on the sunniest place available. Anything from East through South to West is suitable. If it has to face North, don't despair, it will be warmer in than outside! If you can fix to a brick or stone wall, you will get extra heat storage during the day.

**REDUCING THE LENGTH** If it is just too long for your ideal spot, it can be shortened. Re-drill the holes at one end of the rails - moving them in by the amount you need to remove. Hacksaw off the surplus aluminium and shorten the shelf rods and irrigation pipe. The glass will merely overlap more - don't try to cut toughened glass!